

Self-aligning bearings have two rows of balls with a common sphered raceway in the outer ring. This gives the bearings their self-aligning property, permitting angular misalignment of the shaft relative to the housing. They are therefore particularly suitable for applications where misalignment can arise from errors in mounting or from shaft deflection. In addition, non-sealed self-aligning ball bearings have the lowest friction of any bearing type.

Bearing sizes having the E suffix have higher load ratings than the original standard design because of improvements in internal construction. They are supplied with a glass fiber reinforced, 6.6 polyamide cage as standard. Machined brass or pressed steel cages are supplied on other sizes.

Series	Page
100	<b>67</b>
1200, 1200E	<b>67</b>
1300, 1300E	<b>68</b>
1400	<b>68</b>
2200, 2200E	<b>69</b>
2300, 2300E	<b>69</b>
1200K, 1200EK—Tapered Bore	<b>70</b>
1300K, 1300EK—Tapered Bore	<b>70</b>
2200K, 2200EK—Tapered Bore	<b>71</b>
2300K, 2300EK—Tapered Bore	<b>71</b>
1200K, 1200EK—Tapered Bore with Adapter Sleeve	<b>72</b>
1300K, 1300EK—Tapered Bore with Adapter Sleeve	<b>72</b>
2200K, 2200EK—Tapered Bore with Adapter Sleeve	<b>73</b>
2300K, 2300EK—Tapered Bore with Adapter Sleeve	<b>73</b>
2200E2RS1—Two Seals	<b>74</b>
2300E2RS1—Two Seals	<b>74</b>
2200E2RS1K—Two Seals and Tapered Bore	<b>74</b>
11200E—Extended Inner Ring	<b>75</b>
11300E—Extended Inner Ring	<b>75</b>
Internal Clearance	<b>76</b>
Allowable Angular Misalignment	<b>76</b>
Equivalent Load and Life	<b>77</b>
Life Calculation Examples	<b>77</b>
Minimum Required Radial Load	<b>77</b>
Ball Protrusion Beyond Bearing Face	<b>79</b>
Mounting Procedure	<b>80</b>

## Basic Design

Self-aligning bearings of the basic design are available with both a cylindrical bore and a tapered bore with a 1:12 taper. Tapered bore bearings are furnished with adapter sleeves, including nut and lock washer, with which the bearings can be secured to smooth or stepped shafts. They are identified by suffix letter K.

## Sealed Bearings

Self-aligning bearings with cylindrical and tapered bores are available with contact seals on both sides, identified by the suffix 2RS1. The seals are made of oil and wear resistant synthetic rubber reinforced by a steel insert. The operating temperature range for the seals, with a suitable grease, is -40°C to 120°C (-40°F to 248°F). Sealed bearings are supplied with a lithium base grease suitable for an operating temperature range of -30°C to 110°C (-22°F to 230°F).

Sealed bearings with a tapered bore require a special adapter sleeve and lockwasher identified by the suffix letter C. The lockwashers have a circular beading on the side facing the bearing to prevent interference with the seal.

## Extended Inner Ring Bearings

Self-aligning bearings with an extended inner ring are used in applications employing commercial ground shafting. A special bore tolerance allows easy mounting and dismounting.

These bearings are located axially by pins or shouldered screws which engage in a slot at one side of the inner ring. The pins or screws also prevent the inner ring from turning on the shaft. When used in pairs, the slots on the inner ring must either be adjacent or at the outboard positions to provide shaft location in both directions.

## Tolerances

Self-aligning bearings are manufactured to ABEC-1 tolerances as shown on page 241. The exceptions are the bore and inner ring width on extended inner ring bearings, which are manufactured to the tolerances shown in the table below.

All tolerances in ten thousandths inches (.0001) and micrometers (um).

Note: Top figure is inch, bottom is micrometer.

Bore Diameter (mm) Over	Incl	Bore Diameter Tolerance		Bore Out-of-Round (Max)	Inner Ring Width
2.5	10	+3	-3	6	-130
		+8	-8	14	-330
10	18	+3	-3	6	-130
		+8	-8	14	-330
18	30	+4	-4	7	-130
		+10	-10	17	-330
30	50	+5	-5	8	-153
		+12	-12	21	-390
50	80	+6	-6	10	-181
		+15	-15	26	-460



MRC Bearing Number	Bore		Outside Diameter D		Width B		Fillet Radius <sup>1)</sup> r <sub>s</sub>		Calculation Factors				Basic Radial Load Rating				Speed Rating	
									e	Y <sub>1</sub>	Y <sub>2</sub>	Y <sub>0</sub>	Dynamic C <sub>d</sub> <sup>2)</sup>		Static C <sub>0</sub>		Grease RPM	Oil RPM
	d	mm	in	mm	in	mm	in	mm	in					N	lbf	N	lbf	
135	5	.1969	19	.7480	6	.2362	.30	.012	.33	1.9	3	2	2 510	<b>564</b>	480	<b>108</b>	32 000	38 000
126	6	.2362	19	.7480	6	.2362	.30	.012	.33	1.9	3	2	2 510	<b>564</b>	480	<b>108</b>	32 000	38 000
127	7	.2756	22	.8661	7	.2756	.30	.012	.33	1.9	3	2	2 650	<b>596</b>	560	<b>126</b>	30 000	36 000
108	8	.3150	22	.8661	7	.2756	.30	.012	.33	1.9	3	2	2 650	<b>596</b>	560	<b>126</b>	30 000	36 000
129	9	.3543	26	1.0236	8	.3150	.60	.024	.33	1.9	3	2	3 900	<b>877</b>	815	<b>183</b>	26 000	32 000
1200E	10	.3937	30	1.1811	9	.3543	.60	.024	.33	1.9	3	2	5 530	<b>1 240</b>	1 180	<b>265</b>	24 000	30 000
1201E	12	.4724	32	1.2598	10	.3937	.60	.024	.33	1.9	3	2	6 240	<b>1 400</b>	1 430	<b>321</b>	22 000	28 000
1202E	15	.5906	35	1.3780	11	.4331	.60	.024	.33	1.9	3	2	7 410	<b>1 670</b>	1 760	<b>396</b>	19 000	24 000
1203E	17	.6693	40	1.5748	12	.4724	.60	.024	.31	2	3.1	2.2	8 840	<b>1 990</b>	2 200	<b>495</b>	18 000	22 000
1204E	20	.7874	47	1.8504	14	.5512	1.0	.039	.30	2.1	3.3	2.2	12 700	<b>2 860</b>	3 400	<b>764</b>	15 000	18 000
1205E	25	.9843	52	2.0472	15	.5906	1.0	.039	.28	2.2	3.5	2.5	14 300	<b>3 220</b>	4 000	<b>899</b>	13 000	16 000
1206E	30	1.1811	62	2.4409	16	.6299	1.0	.039	.25	2.5	3.9	2.5	15 600	<b>3 510</b>	4 650	<b>1 050</b>	10 000	13 000
1207E	35	1.3780	72	2.8346	17	.6693	1.0	.039	.23	2.7	4.2	2.8	19 000	<b>4 270</b>	6 000	<b>1 350</b>	9 000	11 000
1208E	40	1.5748	80	3.1496	18	.7087	1.0	.039	.22	2.9	4.5	2.8	19 900	<b>4 470</b>	6 950	<b>1 560</b>	8 500	10 000
1209E	45	1.7717	85	3.3465	19	.7480	1.0	.039	.21	3	4.6	3.2	22 900	<b>5 150</b>	7 800	<b>1 750</b>	7 500	9 000
1210E	50	1.9685	90	3.5433	20	.7874	1.0	.039	.21	3	4.6	3.2	26 500	<b>5 960</b>	9 150	<b>2 060</b>	7 000	8 500
1211E	55	2.1654	100	3.9370	21	.8268	1.5	.059	.19	3.3	5.1	3.6	27 600	<b>6 210</b>	10 600	<b>2 380</b>	6 300	7 500
1212E	60	2.3622	110	4.3307	22	.8661	1.5	.059	.19	3.3	5.1	3.6	31 200	<b>7 010</b>	12 200	<b>2 740</b>	5 600	6 700
1213E	65	2.5591	120	4.7244	23	.9055	1.5	.059	.18	3.5	5.4	3.6	35 100	<b>7 890</b>	14 000	<b>3 150</b>	5 300	6 300
1214	70	2.7559	125	4.9213	24	.9449	1.5	.059	.18	3.5	5.4	3.6	34 500	<b>7 760</b>	13 700	<b>3 080</b>	5 000	6 000
1215	75	2.9528	130	5.1181	25	.9843	1.5	.059	.17	3.7	5.7	4	39 000	<b>8 770</b>	15 600	<b>3 510</b>	4 800	5 600
1216	80	3.1496	140	5.5118	26	1.0236	2.0	.079	.16	3.9	6.1	4	39 700	<b>8 930</b>	17 000	<b>3 820</b>	4 500	5 300
1217	85	3.3465	150	5.9055	28	1.1024	2.0	.079	.17	3.7	5.7	4	48 800	<b>11 000</b>	20 800	<b>4 680</b>	4 000	4 800
1218	90	3.5433	160	6.2992	30	1.1811	2.0	.079	.17	3.7	5.7	4	57 200	<b>12 900</b>	23 600	<b>5 310</b>	3 800	4 500
1219	95	3.7402	170	6.6929	32	1.2598	2.0	.079	.17	3.7	5.7	4	63 700	<b>14 300</b>	27 000	<b>6 070</b>	3 600	4 300
1220	100	3.9370	180	7.0866	34	1.3386	2.0	.079	.17	3.7	5.7	4	68 900	<b>15 500</b>	30 000	<b>6 740</b>	3 400	4 000
1221	105	4.1339	190	7.4803	36	1.4173	2.0	.079	.17	3.7	5.7	4	74 100	<b>16 700</b>	32 500	<b>7 310</b>	3 200	3 800
1222	110	4.3307	200	7.8740	38	1.4961	2.0	.079	.17	3.7	5.7	4	88 400	<b>19 900</b>	39 000	<b>8 770</b>	3 000	3 600
1224	120	4.7244	215	8.4646	42	1.6535	2.0	.079	.19	3.3	5.1	3.6	119 000	<b>26 800</b>	53 000	<b>11 900</b>	2 800	3 400
1226	130	5.1181	230	9.0551	46	1.8110	2.5	.098	.19	3.3	5.1	3.6	127 000	<b>28 600</b>	58 500	<b>13 200</b>	2 600	3 200

<sup>1)</sup> Fillet radius indicates maximum fillet radius on shaft or in housing which bearing corner will clear.

<sup>2)</sup> Rating for one million revolutions or 500 hours at 33 1/3 RPM.

# 1300, 1300-E, 1400 Series Self-Aligning Ball Bearings

## MRC Bearing Services



MRC Bearing Number	Bore		Outside Diameter D		Width B		Fillet Radius <sup>1)</sup> r <sub>s</sub>		Calculation Factors				Basic Radial Load Rating				Speed Rating	
	d mm	in	mm	in	mm	in	mm	in	e	Y <sub>1</sub>	Y <sub>2</sub>	Y <sub>0</sub>	Dynamic C <sub>d</sub> <sup>2)</sup>		Static C <sub>0</sub>		Grease RPM	Oil RPM
													N	lbf	N	lbf		
1301E	12	.4724	37	1.4567	12	.4724	1.0	.039	.35	1.8	2.8	1.8	9 360	2 100	2 160	486	18 000	22 000
1302E	15	.5906	42	1.6535	13	.5118	1.0	.039	.31	2	3.1	2.2	10 800	2 430	2 600	585	17 000	20 000
1303E	17	.6693	47	1.8504	14	.5512	1.0	.039	.30	2.1	3.3	2.2	12 700	2 860	3 400	764	14 000	17 000
1304E	20	.7874	52	2.0472	15	.5906	1.0	.039	.28	2.2	3.5	2.5	14 300	3 220	4 000	899	12 000	15 000
1305E	25	.9843	62	2.4409	17	.6693	1.0	.039	.28	2.2	3.5	2.5	19 000	4 270	5 400	1 210	9 500	12 000
1306E	30	1.1811	72	2.8346	19	.7480	1.0	.039	.25	2.5	3.9	2.5	22 500	5 060	6 800	1 530	9 000	11 000
1307E	35	1.3780	80	3.1496	21	.8268	1.5	.059	.25	2.5	3.9	2.5	26 500	5 960	8 500	1 910	7 500	9 000
1308E	40	1.5748	90	3.5433	23	.9055	1.5	.059	.23	2.7	4.2	2.8	33 800	7 600	11 200	2 520	6 700	8 000
1309E	45	1.7717	100	3.9370	25	.9843	1.5	.059	.23	2.7	4.2	2.8	39 000	8 770	13 400	3 010	6 300	7 500
1310E	50	1.9685	110	4.3307	27	1.0630	2.0	.079	.24	2.6	4.1	2.8	43 600	9 800	14 000	3 150	5 600	6 700
1311E	55	2.1654	120	4.7244	29	1.1417	2.0	.079	.23	2.7	4.2	2.8	50 700	11 400	18 000	4 050	5 000	6 000
1312E	60	2.3622	130	5.1181	31	1.2205	2.0	.079	.23	2.7	4.2	2.8	58 500	13 200	22 000	4 950	4 500	5 300
1313E	65	2.5591	140	5.5118	33	1.2992	2.0	.079	.22	2.9	4.5	2.8	65 000	14 600	25 500	5 730	4 300	5 000
1314	70	2.7559	150	5.9055	35	1.3780	2.0	.079	.22	2.9	4.5	2.8	74 100	16 700	27 500	6 180	4 000	4 800
1315	75	2.9528	160	6.2992	37	1.4567	2.0	.079	.22	2.9	4.5	2.8	79 300	17 800	30 000	6 740	3 800	4 500
1316	80	3.1496	170	6.6929	39	1.5354	2.0	.079	.22	2.9	4.5	2.8	88 400	19 900	33 500	7 530	3 600	4 300
1317	85	3.3465	180	7.0866	41	1.6142	2.5	.098	.22	2.9	4.5	2.8	97 500	21 900	38 000	8 540	3 400	4 000
1318	90	3.5433	190	7.4803	43	1.6929	2.5	.098	.22	2.9	4.5	2.8	117 000	26 300	44 000	9 890	3 200	3 800
1319	95	3.7402	200	7.8740	45	1.7717	2.5	.098	.23	2.7	4.2	2.8	133 000	29 900	51 000	11 500	3 000	3 600
1320	100	3.9370	215	8.4646	47	1.8504	2.5	.098	.23	2.7	4.2	2.8	143 000	32 200	57 000	12 800	2 800	3 400
1322	110	4.3307	240	9.4488	50	1.9685	2.5	.098	.22	2.9	4.5	2.8	163 000	36 600	72 000	16 200	2 400	3 000
1406	30	1.1811	90	3.5433	28	1.1024	1.5	.059	.40	1.6	2.4	1.6	59 200	13 300	17 000	3 820	6 700	8 000
1407	35	1.3780	100	3.9370	30	1.1811	1.5	.059	.37	1.7	2.6	1.8	62 400	14 000	18 000	4 050	6 300	7 500
1408	40	1.5748	110	4.3307	33	1.2992	2.0	.079	.35	1.8	2.8	1.8	76 100	17 100	23 600	5 310	5 300	6 300
1409	45	1.7717	120	4.7244	35	1.3780	2.0	.079	.35	1.8	2.8	1.8	88 400	19 900	27 500	6 180	5 000	6 000
1410	50	1.9685	130	5.1181	37	1.4567	2.0	.079	.35	1.8	2.8	1.8	101 000	22 700	32 000	7 190	4 800	5 600
1411	55	2.1654	140	5.5118	40	1.5748	2.0	.079	.33	1.9	3	2	111 000	25 000	36 500	8 210	4 300	5 000
1412	60	2.3622	150	5.9055	42	1.6535	2.0	.079	.33	1.9	3	2	125 000	28 100	41 500	9 330	3 800	4 500

<sup>1)</sup> Fillet radius indicates maximum fillet radius on shaft or in housing which bearing corner will clear.

<sup>2)</sup> Rating for one million revolutions or 500 hours at 33 1/3 RPM.



1) Fillet radius here

MRC Bearing Number	Bore		Outside Diameter D		Width B		Fillet Radius <sup>1)</sup> r <sub>s</sub>		Calculation Factors				Basic Radial Load Rating				Speed Rating	
									e	Y <sub>1</sub>	Y <sub>2</sub>	Y <sub>0</sub>	Dynamic C <sub>d</sub> <sup>2)</sup>		Static C <sub>0</sub>		Grease RPM	Oil RPM
	d	in	mm	in	mm	in	mm	in					N	lbf	N	lbf		
2200E	10	.3937	30	1.1811	14	.5512	.60	.024	.54	1.15	1.8	1.3	8 060	<b>1 810</b>	1 730	<b>389</b>	22 000	28 000
2201E	12	.4724	32	1.2598	14	.5512	.60	.024	.50	1.25	2	1.3	8 520	<b>1 920</b>	1 900	<b>427</b>	20 000	26 000
2202E	15	.5906	35	1.3780	14	.5512	.60	.024	.43	1.5	2.3	1.6	8 710	<b>1 960</b>	2 040	<b>459</b>	18 000	22 000
2203E	17	.6693	40	1.5748	16	.6299	.60	.024	.43	1.5	2.3	1.6	10 600	<b>2 380</b>	2 550	<b>573</b>	17 000	20 000
2204E	20	.7874	47	1.8504	18	.7087	1.0	.039	.40	1.6	2.4	1.6	16 800	<b>3 780</b>	4 150	<b>933</b>	14 000	17 000
2205E	25	.9843	52	2.0472	18	.7087	1.0	.039	.35	1.8	2.8	1.8	16 800	<b>3 780</b>	4 400	<b>989</b>	11 000	14 000
2206E	30	1.1811	62	2.4409	20	.7874	1.0	.039	.33	1.9	3	2	23 800	<b>5 350</b>	6 700	<b>1 510</b>	9 500	12 000
2207E	35	1.3780	72	2.8346	23	.9055	1.0	.039	.31	2	3.1	2.2	30 700	<b>6 900</b>	8 800	<b>1 980</b>	8 500	10 000
2208E	40	1.5748	80	3.1496	23	.9055	1.0	.039	.28	2.2	3.5	2.5	31 900	<b>7 170</b>	10 000	<b>2 250</b>	7 500	9 000
2209E	45	1.7717	85	3.3465	23	.9055	1.0	.039	.26	2.4	3.7	2.5	32 500	<b>7 310</b>	10 600	<b>2 380</b>	7 000	8 500
2210E	50	1.9685	90	3.5433	23	.9055	1.0	.039	.23	2.7	4.2	2.8	33 800	<b>7 600</b>	11 200	<b>2 520</b>	6 300	7 500
2211E	55	2.1654	100	3.9370	25	.9843	1.5	.059	.23	2.7	4.2	2.8	39 000	<b>8 770</b>	13 400	<b>3 010</b>	6 000	7 000
2212E	60	2.3622	110	4.3307	28	1.1024	1.5	.059	.24	2.6	4.1	2.8	48 800	<b>11 000</b>	17 000	<b>3 820</b>	5 300	6 300
2213E	65	2.5591	120	4.7244	31	1.2205	1.5	.059	.24	2.6	4.1	2.8	57 200	<b>12 900</b>	20 000	<b>4 500</b>	5 000	6 000
2214	70	2.7559	125	4.9213	31	1.2205	1.5	.059	.27	2.3	3.6	2.5	44 200	<b>9 940</b>	17 000	<b>3 820</b>	4 800	5 600
2215	75	2.9528	130	5.1181	31	1.2205	1.5	.059	.25	2.5	3.9	2.5	44 200	<b>9 940</b>	18 000	<b>4 050</b>	4 500	5 300
2216E	80	3.1496	140	5.5118	33	1.2992	2.0	.079	.22	2.9	4.5	2.8	65 000	<b>14 600</b>	25 500	<b>5 730</b>	4 000	4 800
2217	85	3.3465	150	5.9055	36	1.4173	2.0	.079	.25	2.5	3.9	2.5	58 500	<b>13 200</b>	23 600	<b>5 310</b>	3 800	4 500
2218	90	3.5433	160	6.2992	40	1.5748	2.0	.079	.27	2.3	3.6	2.5	70 200	<b>15 800</b>	28 500	<b>6 410</b>	3 600	4 300
2219	95	3.7402	170	6.6929	43	1.6929	2.0	.079	.27	2.3	3.6	2.5	83 200	<b>18 700</b>	34 500	<b>7 760</b>	3 400	4 000
2220	100	3.9370	180	7.0866	46	1.8110	2.0	.079	.27	2.3	3.6	2.5	97 500	<b>21 900</b>	40 500	<b>9 110</b>	3 200	3 800
2221	105	4.1339	190	7.4803	50	1.9685	2.0	.079	.28	2.2	3.5	2.5	108 000	<b>24 300</b>	45 000	<b>10 100</b>	3 000	3 600
2222	110	4.3307	200	7.8740	53	2.0866	2.0	.079	.28	2.2	3.5	2.5	124 000	<b>27 900</b>	52 000	<b>11 700</b>	2 800	3 400
2301	12	.4724	37	1.4567	17	.6693	1.0	.039	.60	1.05	1.6	1.1	11 700	<b>2 630</b>	2 700	<b>607</b>	17 000	20 000
2302	15	.5906	42	1.6535	17	.6693	1.0	.039	.52	1.2	1.9	1.3	11 900	<b>2 680</b>	2 900	<b>652</b>	15 000	18 000
2303	17	.6693	47	1.8504	19	.7480	1.0	.039	.52	1.2	1.9	1.3	14 600	<b>3 280</b>	3 550	<b>798</b>	13 000	16 000
2304	20	.7874	52	2.0472	21	.8268	1.0	.039	.52	1.2	1.9	1.3	18 200	<b>4 090</b>	4 750	<b>1 070</b>	11 000	14 000
2305	25	.9843	62	2.4409	24	.9449	1.0	.039	.48	1.3	2	1.4	24 200	<b>5 440</b>	6 550	<b>1 470</b>	9 500	12 000
2306	30	1.1811	72	2.8346	27	1.0630	1.0	.039	.44	1.4	2.2	1.4	31 200	<b>7 010</b>	8 800	<b>1 980</b>	8 500	10 000
2307E	35	1.3780	80	3.1496	31	1.2205	1.5	.059	.46	1.35	2.1	1.4	39 700	<b>8 930</b>	11 200	<b>2 520</b>	7 000	8 500
2308E	40	1.5748	90	3.5433	33	1.2992	1.5	.059	.40	1.6	2.4	1.6	54 000	<b>12 100</b>	16 000	<b>3 600</b>	6 300	7 500
2309E	45	1.7717	100	3.9370	36	1.4173	1.5	.059	.33	1.9	3	2	63 700	<b>14 300</b>	19 300	<b>4 340</b>	5 600	6 700
2310	50	1.9685	110	4.3307	40	1.5748	2.0	.079	.43	1.5	2.3	1.6	63 700	<b>14 300</b>	20 000	<b>4 500</b>	5 300	6 300
2311	55	2.1654	120	4.7244	43	1.6929	2.0	.079	.40	1.6	2.4	1.6	76 100	<b>17 100</b>	24 000	<b>5 400</b>	4 800	5 600
2312	60	2.3622	130	5.1181	46	1.8110	2.0	.079	.33	1.9	3	2	87 100	<b>19 600</b>	28 500	<b>6 410</b>	4 500	5 300
2313	65	2.5591	140	5.5118	48	1.8898	2.0	.079	.37	1.7	2.6	1.8	95 600	<b>21 500</b>	32 500	<b>7 310</b>	4 000	4 800
2314	70	2.7559	150	5.9055	51	2.0079	2.0	.079	.37	1.7	2.6	1.8	111 000	<b>25 000</b>	37 500	<b>8 430</b>	3 800	4 500
2315	75	2.9528	160	6.2992	55	2.1654	2.0	.079	.37	1.7	2.6	1.8	124 000	<b>27 900</b>	43 000	<b>9 670</b>	3 400	4 000
2316	80	3.1496	170	6.6929	58	2.2835	2.0	.079	.37	1.7	2.6	1.8	135 000	<b>30 400</b>	49 000	<b>11 000</b>	3 200	3 800
2317	85	3.3465	180	7.0866	60	2.3622	2.5	.098	.37	1.7	2.6	1.8	140 000	<b>31 500</b>	51 000	<b>11 500</b>	3 000	3 600
2318	90	3.5433	190	7.4803	64	2.5197	2.5	.098	.37	1.7	2.6	1.8	153 000	<b>34 400</b>	57 000	<b>12 800</b>	2 800	3 400
2319	95	3.7402	200	7.8740	67	2.6378	2.5	.098	.37	1.7	2.6	1.8	165 000	<b>37 100</b>	64 000	<b>14 400</b>	2 600	3 200
2320	100	3.9370	215	8.4646	73	2.8740	2.5	.098	.37	1.7	2.6	1.8	190 000	<b>42 700</b>	80 000	<b>18 000</b>	2 400	3 000
2322	110	4.3307	240	9.4488	80	3.1496	2.5	.098	.37	1.7	2.6	1.8	216 000	<b>48 600</b>	95 000	<b>21 400</b>	2 200	2 800

<sup>1)</sup> Fillet radius indicates maximum fillet radius on shaft or in housing which bearing corner will clear.

<sup>2)</sup> Rating for one million revolutions or 500 hours at 33 1/3 RPM.

# 1200-K, 1200-EK, 1300-K, 1300-EK Series Self-Aligning Ball Bearings with Tapered Bore

MRC Bearing Services

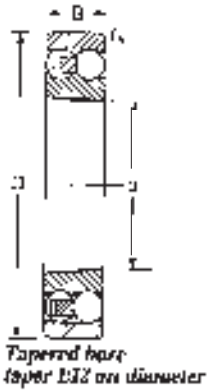

MRC Bearing Number	Bore		Outside Diameter D		Width B		Fillet Radius <sup>1)</sup> r <sub>s</sub>		Calculation Factors				Basic Radial Load Rating				Speed Rating	
	d mm	in	mm	in	mm	in	mm	in	e	Y <sub>1</sub>	Y <sub>2</sub>	Y <sub>0</sub>	Dynamic C <sub>d</sub> <sup>2)</sup>		Static C <sub>0</sub>		Grease RPM	Oil RPM
													N	lbf	N	lbf		
1204EK	20	.7874	47	1.8504	14	.5512	1.0	.039	.30	2.1	3.3	2.2	12 700	2 860	3 400	764	15 000	18 000
1205EK	25	.9843	52	2.0472	15	.5906	1.0	.039	.28	2.2	3.5	2.5	14 300	3 220	4 000	899	13 000	16 000
1206EK	30	1.1811	62	2.4409	16	.6299	1.0	.039	.25	2.5	3.9	2.5	15 600	3 510	4 650	1 050	10 000	13 000
1207EK	35	1.3780	72	2.8346	17	.6693	1.0	.039	.23	2.7	4.2	2.8	19 000	4 270	6 000	1 350	9 000	11 000
1208EK	40	1.5748	80	3.1496	18	.7087	1.0	.039	.22	2.9	4.5	2.8	19 900	4 470	6 950	1 560	8 500	10 000
1209EK	45	1.7717	85	3.3465	19	.7480	1.0	.039	.21	3	4.6	3.2	22 900	5 150	7 800	1 750	7 500	9 000
1210EK	50	1.9685	90	3.5433	20	.7874	1.0	.039	.21	3	4.6	3.2	26 500	5 960	9 150	2 060	7 000	8 500
1211EK	55	2.1654	100	3.9370	21	.8268	1.5	.059	.19	3.3	5.1	3.6	27 600	6 210	10 600	2 380	6 300	7 500
1212EK	60	2.3622	110	4.3307	22	.8661	1.5	.059	.19	3.3	5.1	3.6	31 200	7 010	12 200	2 740	5 600	6 700
1213EK	65	2.5591	120	4.7244	23	.9055	1.5	.059	.18	3.5	5.4	3.6	35 100	7 890	14 000	3 150	5 300	6 300
1215K	75	2.9528	130	5.1181	25	.9843	1.5	.059	.17	3.7	5.7	4	39 000	8 770	15 600	3 510	4 800	5 600
1216K	80	3.1496	140	5.5118	26	1.0236	2.0	.079	.16	3.9	6.1	4	39 700	8 930	17 000	3 820	4 500	5 300
1217K	85	3.3465	150	5.9055	28	1.1024	2.0	.079	.17	3.7	5.7	4	48 800	11 000	20 800	4 680	4 000	4 800
1218K	90	3.5433	160	6.2992	30	1.1811	2.0	.079	.17	3.7	5.7	4	57 200	12 900	23 600	5 310	3 800	4 500
1219K	95	3.7402	170	6.6929	32	1.2598	2.0	.079	.17	3.7	5.7	4	63 700	14 300	27 000	6 070	3 600	4 300
1220K	100	3.9370	180	7.0866	34	1.3386	2.0	.079	.17	3.7	5.7	4	68 900	15 500	30 000	6 740	3 400	4 000
1221K	105	4.1339	190	7.4803	36	1.4173	2.0	.079	.17	3.7	5.7	4	74 100	16 700	32 500	7 310	3 200	3 800
1222K	110	4.3307	200	7.8740	38	1.4961	2.0	.079	.17	3.7	5.7	4	88 400	19 900	39 000	8 770	3 000	3 600
1224K	120	4.7244	215	8.4646	42	1.6535	2.0	.079	.19	3.3	5.1	3.6	11 900	26 800	53 000	11 900	2 800	3 400
1304EK	20	.7874	52	2.0472	15	.5906	1.0	.039	.28	2.2	3.5	2.5	14 300	3 220	4 000	899	12 000	15 000
1305EK	25	.9843	62	2.4409	17	.6693	1.0	.039	.28	2.2	3.5	2.5	19 000	4 270	5 400	1 210	9 500	12 000
1306EK	30	1.1811	72	2.8346	19	.7480	1.0	.039	.25	2.5	3.9	2.5	22 500	5 060	6 800	1 530	9 000	11 000
1307EK	35	1.3780	80	3.1496	21	.8268	1.5	.059	.25	2.5	3.9	2.5	26 500	5 960	8 500	1 910	7 500	9 000
1308EK	40	1.5748	90	3.5433	23	.9055	1.5	.059	.23	2.7	4.2	2.8	33 800	7 600	11 200	2 520	6 700	8 000
1309EK	45	1.7717	100	3.9370	25	.9843	1.5	.059	.23	2.7	4.2	2.8	39 000	8 770	13 400	3 010	6 300	7 500
1310EK	50	1.9685	110	4.3307	27	1.0630	2.0	.079	.24	2.6	4.1	2.8	43 600	9 800	14 000	3 150	5 600	6 700
1311EK	55	2.1654	120	4.7244	29	1.1417	2.0	.079	.23	2.7	4.2	2.8	50 700	11 400	18 000	4 050	5 000	6 000
1312EK	60	2.3622	130	5.1181	31	1.2205	2.0	.079	.23	2.7	4.2	2.8	58 500	13 200	22 000	4 950	4 500	5 300
1313EK	65	2.5591	140	5.5118	33	1.2992	2.0	.079	.22	2.9	4.5	2.8	65 000	14 600	25 500	5 730	4 300	5 000
1315K	75	2.9528	160	6.2992	37	1.4567	2.0	.079	.22	2.9	4.5	2.8	79 300	17 800	30 000	6 740	3 800	4 500
1316K	80	3.1496	170	6.6929	39	1.5354	2.0	.079	.22	2.9	4.5	2.8	88 400	19 900	33 500	7 530	3 600	4 300
1317K	85	3.3465	180	7.0866	41	1.6142	2.5	.098	.22	2.9	4.5	2.8	97 500	21 900	38 000	8 540	3 400	4 000
1318K	90	3.5433	190	7.4803	43	1.6929	2.5	.098	.22	2.9	4.5	2.8	117 000	26 300	44 000	9 890	3 200	3 800
1319K	95	3.7402	200	7.8740	45	1.7717	2.5	.098	.23	2.7	4.2	2.8	133 000	29 900	51 000	11 500	3 000	3 600
1320K	100	3.9370	215	8.4646	47	1.8504	2.5	.098	.23	2.7	4.2	2.8	143 000	32 200	57 000	12 800	2 800	3 400
1322K	110	4.3307	240	9.4488	50	1.9685	2.5	.098	.22	2.9	4.5	2.8	163 000	36 600	72 000	16 200	2 400	3 000

<sup>1)</sup> Fillet radius indicates maximum fillet radius on shaft or in housing which bearing corner will clear.

<sup>2)</sup> Rating for one million revolutions or 500 hours at 33 1/3 RPM.

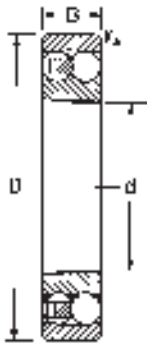

Tapered bore  
taper 1:12 on diameter

MRC Bearing Number	Bore		Outside Diameter D		Width B		Fillet Radius <sup>1)</sup> r <sub>s</sub>		Calculation Factors				Basic Radial Load Rating				Speed Rating	
									e	Y <sub>1</sub>	Y <sub>2</sub>	Y <sub>0</sub>	Dynamic C <sub>d</sub> <sup>2)</sup>		Static C <sub>0</sub>		Grease RPM	Oil RPM
	d	mm	in	mm	in	mm	in	mm	in					N	lbf	N	lbf	
2205EK	25	.9843	52	2.0472	18	.7087	1.0	.039	.35	1.8	2.8	1.8	16 800	<b>3 780</b>	4 400	<b>989</b>	11 000	14 000
2206EK	30	1.1811	62	2.4409	20	.7874	1.0	.039	.33	1.9	3	2	23 800	<b>5 350</b>	6 700	<b>1 510</b>	9 500	12 000
2207EK	35	1.3780	72	2.8346	23	.9055	1.0	.039	.31	2	3.1	2.2	30 700	<b>6 900</b>	8 800	<b>1 980</b>	8 500	10 000
2208EK	40	1.5748	80	3.1496	23	.9055	1.0	.039	.28	2.2	3.5	2.5	31 900	<b>7 170</b>	10 000	<b>2 250</b>	7 500	9 000
2209EK	45	1.7717	85	3.3465	23	.9055	1.0	.039	.26	2.4	3.7	2.5	32 500	<b>7 310</b>	10 600	<b>2 380</b>	7 000	8 500
2210EK	50	1.9685	90	3.5433	23	.9055	1.0	.039	.23	2.7	4.2	2.8	33 800	<b>7 600</b>	11 200	<b>2 520</b>	6 300	7 500
2211EK	55	2.1654	100	3.9370	25	.9843	1.5	.059	.23	2.7	4.2	2.8	39 000	<b>8 770</b>	13 400	<b>3 010</b>	6 000	7 000
2212EK	60	2.3622	110	4.3307	28	1.1024	1.5	.059	.24	2.6	4.1	2.8	48 800	<b>11 000</b>	17 000	<b>3 820</b>	5 300	6 300
2213EK	65	2.5591	120	4.7244	31	1.2205	1.5	.059	.24	2.6	4.1	2.8	57 200	<b>12 900</b>	20 000	<b>4 500</b>	5 000	6 000
2215K	75	2.9528	130	5.1181	31	1.2205	1.5	.059	.25	2.5	3.9	2.5	44 200	<b>9 940</b>	18 000	<b>4 050</b>	4 500	5 300
2216EK	80	3.1496	140	5.5118	33	1.2992	2.0	.079	.22	2.9	4.5	2.8	65 000	<b>14 600</b>	25 500	<b>5 730</b>	4 000	4 800
2217K	85	3.3465	150	5.9055	36	1.4173	2.0	.079	.25	2.5	3.9	2.5	58 500	<b>13 200</b>	23 600	<b>5 310</b>	3 800	4 500
2218K	90	3.5433	160	6.2992	40	1.5748	2.0	.079	.27	2.3	3.6	2.5	70 200	<b>15 800</b>	28 500	<b>6 410</b>	3 600	4 300
2219K	95	3.7402	170	6.6929	43	1.6929	2.0	.079	.27	2.3	3.6	2.5	83 200	<b>18 700</b>	34 500	<b>7 760</b>	3 400	4 000
2220K	100	3.9370	180	7.0866	46	1.8110	2.0	.079	.27	2.3	3.6	2.5	97 500	<b>21 900</b>	40 500	<b>9 110</b>	3 200	3 800
2221K	105	4.1339	190	7.4803	50	1.9685	2.0	.079	.28	2.2	3.5	2.5	108 000	<b>24 300</b>	45 000	<b>10 100</b>	3 000	3 600
2222K	110	4.3307	200	7.8740	53	2.0866	2.0	.079	.28	2.2	3.5	2.5	124 000	<b>27 900</b>	52 000	<b>11 700</b>	2 800	3 400
2305K	25	.9843	62	2.4409	24	.9449	1.0	.039	.48	1.3	2	1.4	24 200	<b>5 440</b>	6 550	<b>1 470</b>	9 500	12 000
2306K	30	1.1811	72	2.8346	27	1.0630	1.0	.039	.44	1.4	2.2	1.4	31 200	<b>7 010</b>	8 800	<b>1 980</b>	8 500	10 000
2307EK	35	1.3780	80	3.1496	31	1.2205	1.5	.059	.46	1.35	2.1	1.4	39 700	<b>8 930</b>	11 200	<b>2 520</b>	7 000	8 500
2308EK	40	1.5748	90	3.5433	33	1.2992	1.5	.059	.40	1.6	2.4	1.6	54 000	<b>12 100</b>	16 000	<b>3 600</b>	6 300	7 500
2309EK	45	1.7717	100	3.9370	36	1.4173	1.5	.059	.33	1.9	3	2	63 700	<b>14 300</b>	19 300	<b>4 340</b>	5 600	6 700
2310K	50	1.9685	110	4.3307	40	1.5748	2.0	.079	.43	1.5	2.3	1.6	63 700	<b>14 300</b>	20 000	<b>4 500</b>	5 300	6 300
2311K	55	2.1654	120	4.7244	43	1.6929	2.0	.079	.40	1.6	2.4	1.6	76 100	<b>17 100</b>	24 000	<b>5 400</b>	4 800	5 600
2312K	60	2.3622	130	5.1181	46	1.8110	2.0	.079	.33	1.9	3	2	87 100	<b>19 600</b>	28 500	<b>6 410</b>	4 500	5 300
2313K	65	2.5591	140	5.5118	48	1.8898	2.0	.079	.37	1.7	2.6	1.8	95 600	<b>21 500</b>	32 500	<b>7 310</b>	4 000	4 800
2315K	75	2.9528	160	6.2992	55	2.1654	2.0	.079	.37	1.7	2.6	1.8	124 000	<b>27 900</b>	43 000	<b>9 670</b>	3 400	4 000
2316K	80	3.1496	170	6.6929	58	2.2835	2.0	.079	.37	1.7	2.6	1.8	135 000	<b>30 400</b>	49 000	<b>11 000</b>	3 200	3 800
2317K	85	3.3465	180	7.0866	60	2.3622	2.5	.098	.37	1.7	2.6	1.8	140 000	<b>31 500</b>	51 000	<b>11 500</b>	3 000	3 600
2318K	90	3.5433	190	7.4803	64	2.5197	2.5	.098	.37	1.7	2.6	1.8	153 000	<b>34 400</b>	57 000	<b>12 800</b>	2 800	3 400
2319K	95	3.7402	200	7.8740	67	2.6378	2.5	.098	.37	1.7	2.6	1.8	165 000	<b>37 100</b>	64 000	<b>14 400</b>	2 600	3 200
2320K	100	3.9370	215	8.4646	73	2.8740	2.5	.098	.37	1.7	2.6	1.8	190 000	<b>42 700</b>	80 000	<b>18 000</b>	2 400	3 000
2322K	110	4.3307	240	9.4488	80	3.1496	2.5	.098	.37	1.7	2.6	1.8	216 000	<b>48 600</b>	95 000	<b>21 400</b>	2 200	2 800

<sup>1)</sup> Fillet radius indicates maximum fillet radius on shaft or in housing which bearing corner will clear.

<sup>2)</sup> Rating for one million revolutions or 500 hours at 33 1/3 RPM.

**1200-K, 1200-EK, 1300-K, 1300-EK**  
**Self-Aligning Series with Adapter Sleeve**

**MRC Bearing Services**

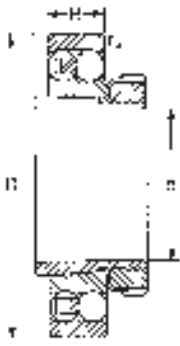

Tapered Bore  
Taper 1:12 on ID.

MRC Bearing Number	Adapter Sleeve	Bore		Outside Diameter D		Width B		Fillet Radius <sup>1)</sup>		Calculation Factors				Basic Radial Load Rating				Speed Rating	
		d						r <sub>a</sub>		e	Y <sub>1</sub>	Y <sub>2</sub>	Y <sub>0</sub>	Dynamic C <sup>2)</sup>		Static C <sub>0</sub>		Grease RPM	Oil RPM
		mm	in	mm	in	mm	in	mm	in	N	lbf	N	lbf						
1204EK	H204	17	.6693	47	1.8504	14	.5512	1.0	.039	.30	2.1	3.3	2.2	12 700	2 860	3 400	764	15 000	18 000
1205EK	H205	20	.7874	52	2.0472	15	.5906	1.0	.039	.28	2.2	3.5	2.5	14 300	3 220	4 000	899	13 000	16 000
1206EK	H206	25	.9843	62	2.4409	16	.6299	1.0	.039	.25	2.5	3.9	2.5	15 600	3 510	4 650	1 050	10 000	13 000
1207EK	H207	30	1.1811	72	2.8346	17	.6693	1.0	.039	.23	2.7	4.2	2.8	19 000	4 270	6 000	1 350	9 000	11 000
1208EK	H208	35	1.3780	80	3.1496	18	.7087	1.0	.039	.22	2.9	4.5	2.8	19 900	4 470	6 950	1 560	8 500	10 000
1209EK	H209	40	1.5748	85	3.3465	19	.7480	1.0	.039	.21	3	4.6	3.2	22 900	5 150	7 800	1 750	7 500	9 000
1210EK	H210	45	1.7717	90	3.5433	20	.7874	1.0	.039	.21	3	4.6	3.2	26 500	5 960	9 150	2 060	7 000	8 500
1211EK	H211	50	1.9685	100	3.9370	21	.8268	1.5	.059	.19	3.3	5.1	3.6	27 600	6 210	10 600	2 380	6 300	7 500
1212EK	H212	55	2.1654	110	4.3307	22	.8661	1.5	.059	.19	3.3	5.1	3.6	31 200	7 010	12 200	2 740	5 600	6 700
1213EK	H213	60	2.3622	120	4.7244	23	.9055	1.5	.059	.18	3.5	5.4	3.6	35 100	7 890	14 000	3 150	5 300	6 300
1215K	H215	65	2.5591	130	5.1181	25	.9843	1.5	.059	.17	3.7	5.7	4	39 000	8 770	15 600	3 510	4 800	5 600
1216K	H216	70	2.7559	140	5.5118	26	1.0236	2.0	.079	.16	3.9	6.1	4	39 700	8 930	17 000	3 820	4 500	5 300
1217K	H217	75	2.9528	150	5.9055	28	1.1024	2.0	.079	.17	3.7	5.7	4	48 800	11 000	20 800	4 680	4 000	4 800
1218K	H218	80	3.1496	160	6.2992	30	1.1811	2.0	.079	.17	3.7	5.7	4	57 200	12 900	23 600	5 310	3 800	4 500
1219K	H219	85	3.3465	170	6.6929	32	1.2598	2.0	.079	.17	3.7	5.7	4	63 700	14 300	27 000	6 070	3 600	4 300
1220K	H220	90	3.5433	180	7.0866	34	1.3386	2.0	.079	.17	3.7	5.7	4	68 900	15 500	30 000	6 740	3 400	4 000
1221K	H221	95	3.7402	190	7.4803	36	1.4173	2.0	.079	.17	3.7	5.7	4	74 100	16 700	32 500	7 310	3 200	3 800
1222K	H222	100	3.9370	200	7.8740	38	1.4961	2.0	.079	.17	3.7	5.7	4	88 400	19 900	39 000	8 770	3 000	3 600
1224K	H3024	110	4.3307	215	8.4646	42	1.6535	2.0	.079	.19	3.3	5.1	3.6	119 000	26 800	53 000	11 900	2 800	3 400
1304EK	H304	17	.6693	52	2.0472	15	.5906	1.0	.039	.28	2.2	3.5	2.5	14 300	3 220	4 000	899	12 000	14 000
1305EK	H305	20	.7874	62	2.4409	17	.6693	1.0	.039	.28	2.2	3.5	2.5	19 000	4 270	5 400	1 210	9 500	12 000
1306EK	H306	25	.9843	72	2.8346	19	.7480	1.0	.039	.25	2.5	3.9	2.5	25 500	5 060	6 800	1 530	9 000	11 000
1307EK	H307	30	1.1811	80	3.1496	21	.8268	1.5	.059	.25	2.5	3.9	2.5	26 500	5 960	8 500	1 910	7 500	9 000
1308EK	H308	35	1.3780	90	3.5433	23	.9055	1.5	.059	.23	2.7	4.2	2.8	33 800	7 600	11 200	2 520	6 700	8 000
1309EK	H309	40	1.5748	100	3.9370	25	.9843	1.5	.059	.23	2.7	4.2	2.8	39 000	8 770	13 400	3 010	6 300	7 500
1310EK	H310	45	1.7717	110	4.3307	27	1.0630	2.0	.079	.24	2.6	4.1	2.8	43 600	9 800	14 000	3 150	5 600	6 700
1311EK	H311	50	1.9685	120	4.7244	29	1.1417	2.0	.079	.23	2.7	4.2	2.8	50 700	11 400	18 000	4 050	5 000	6 000
1312EK	H312	55	2.1654	130	5.1181	31	1.2205	2.0	.079	.23	2.7	4.2	2.8	58 500	13 200	22 000	4 950	4 500	5 300
1313EK	H313	60	2.3622	140	5.5118	33	1.2992	2.0	.079	.22	2.9	4.5	2.8	65 000	14 600	25 500	5 730	4 300	5 000
1315K	H315	65	2.5591	160	6.2992	37	1.4567	2.0	.079	.22	2.9	4.5	2.8	79 300	17 800	30 000	6 740	3 800	4 500
1316K	H316	70	2.7559	170	6.6929	39	1.5354	2.0	.079	.22	2.9	4.5	2.8	88 400	19 900	33 500	7 530	3 600	4 300
1317K	H317	75	2.9528	180	7.0866	41	1.6142	2.5	.098	.22	2.9	4.5	2.8	97 500	21 900	38 000	8 540	3 400	4 000
1318K	H318	80	3.1496	190	7.4803	43	1.6929	2.5	.098	.22	2.9	4.5	2.8	117 000	26 300	44 000	9 890	3 200	3 800
1319K	H319	85	3.3465	200	7.8740	45	1.7717	2.5	.098	.23	2.7	4.2	2.8	133 000	29 900	51 000	11 500	3 000	3 600
1320K	H320	90	3.5433	215	8.4646	47	1.8504	2.5	.098	.23	2.7	4.2	2.8	143 000	32 200	57 000	12 800	2 800	3 400
1322K	H322	100	3.9370	240	9.4488	50	1.9685	2.5	.098	.22	2.9	4.5	2.8	163 000	36 600	72 000	16 200	2 400	3 000

<sup>1)</sup> Fillet radius indicates maximum fillet radius on shaft or in housing which bearing corner will clear.

<sup>2)</sup> Rating for one million revolutions or 500 hours at 33 1/3 RPM.



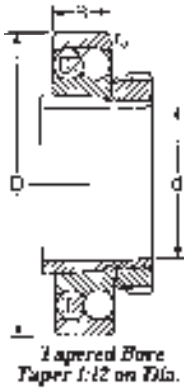

MRC Bearing Number	Adapter Sleeve	Bore d mm in		Outside Diameter D mm in		Width B mm in		Fillet Radius <sup>1)</sup> r <sub>a</sub> mm in		Calculation Factors				Basic Radial Load Rating				Speed Rating	
										e	Y <sub>1</sub>	Y <sub>2</sub>	Y <sub>0</sub>	Dynamic C <sup>2)</sup>		Static C <sub>0</sub>		Grease RPM	Oil RPM
														N	lbf	N	lbf		
2205EK	H305	20	.7874	52	2.0472	18	.7087	1.0	.039	.35	1.8	2.8	1.8	16 800	<b>3 780</b>	4 400	<b>989</b>	11 000	14 000
2206EK	H306	25	.9843	62	2.4409	20	.7874	1.0	.039	.33	1.9	3	2	23 800	<b>5 350</b>	6 700	<b>1 510</b>	9 500	12 000
2207EK	H307	30	1.1811	72	2.8346	23	.9055	1.0	.039	.31	2	3.1	2.2	30 700	<b>6 900</b>	8 800	<b>1 980</b>	8 500	10 000
2208EK	H308	35	1.3780	80	3.1496	23	.9055	1.0	.039	.28	2.2	3.5	2.5	31 900	<b>7 170</b>	10 000	<b>2 250</b>	7 500	9 000
2209EK	H309	40	1.5748	85	3.3465	23	.9055	1.0	.039	.26	2.4	3.7	2.5	32 500	<b>7 310</b>	10 600	<b>2 380</b>	7 000	8 500
2210EK	H310	45	1.7717	90	3.5433	23	.9055	1.0	.039	.23	2.7	4.2	2.8	33 800	<b>7 600</b>	11 200	<b>2 520</b>	6 300	7 500
2211EK	H311	50	1.9685	100	3.9370	25	.9843	1.5	.059	.23	2.7	4.2	2.8	39 000	<b>8 770</b>	13 400	<b>3 010</b>	6 000	7 000
2212EK	H312	55	2.1654	110	4.3307	28	1.1024	1.5	.059	.24	2.6	4.1	2.8	48 800	<b>11 000</b>	17 000	<b>3 820</b>	5 300	6 300
2213EK	H313	60	2.3622	120	4.7244	31	1.2205	1.5	.059	.24	2.6	4.1	2.8	57 200	<b>12 900</b>	20 000	<b>4 500</b>	5 000	6 000
2215K	H315	65	2.5591	130	5.1181	31	1.2205	1.5	.059	.25	2.5	3.9	2.5	44 200	<b>9 940</b>	18 000	<b>4 050</b>	4 500	5 300
2216EK	H316	70	2.7559	140	5.5118	33	1.2992	2.0	.079	.22	2.9	4.5	2.8	65 000	<b>14 600</b>	25 500	<b>5 730</b>	4 000	4 800
2217K	H317	75	2.9528	150	5.9055	36	1.4173	2.0	.079	.25	2.5	3.9	2.5	58 500	<b>13 200</b>	23 600	<b>5 310</b>	3 800	4 500
2218K	H318	80	3.1496	160	6.2992	40	1.5748	2.0	.079	.27	2.3	3.6	2.5	70 200	<b>15 800</b>	28 500	<b>6 410</b>	3 600	4 300
2219K	H319	85	3.3465	170	6.6929	43	1.6929	2.0	.079	.27	2.3	3.6	2.5	83 200	<b>18 700</b>	34 500	<b>7 760</b>	3 400	4 000
2220K	H320	90	3.5433	180	7.0866	46	1.8110	2.0	.079	.27	2.3	3.6	2.5	97 500	<b>21 900</b>	40 500	<b>9 110</b>	3 200	3 800
2221K	H321	95	3.7402	190	7.4803	50	1.9685	2.0	.079	.28	2.2	3.5	2.5	108 000	<b>24 300</b>	45 000	<b>10 100</b>	3 000	3 600
2222K	H322	100	3.9370	200	7.8740	53	2.0866	2.0	.079	.28	2.2	3.5	2.5	124 000	<b>27 900</b>	52 000	<b>11 700</b>	2 800	3 400
2305K	H2305	20	.7874	62	2.4409	24	.9449	1.0	.039	.48	1.3	2	1.4	24 200	<b>5 440</b>	6 550	<b>1 470</b>	9 500	12 000
2306K	H2306	25	.9843	72	2.8346	27	1.0630	1.0	.039	.44	1.4	2.2	1.4	31 200	<b>7 010</b>	8 800	<b>1 980</b>	8 500	10 000
2307EK	H2307	30	1.1811	80	3.1496	31	1.2205	1.5	.059	.46	1.35	2.1	1.4	39 700	<b>8 930</b>	11 200	<b>2 520</b>	7 000	8 500
2308EK	H2308	35	1.3780	90	3.5433	33	1.2992	1.5	.059	.40	1.6	2.4	1.6	54 000	<b>12 100</b>	16 000	<b>3 600</b>	6 300	7 500
2309EK	H2309	40	1.5748	100	3.9370	36	1.4173	1.5	.059	.33	1.9	3	2	63 700	<b>14 300</b>	19 300	<b>4 340</b>	5 600	6 700
2310K	H2310	45	1.7717	110	4.3307	40	1.5748	2.0	.079	.43	1.5	2.3	1.6	63 700	<b>14 300</b>	20 000	<b>4 500</b>	5 300	6 300
2311K	H2311	50	1.9685	120	4.7244	43	1.6929	2.0	.079	.40	1.6	2.4	1.6	76 100	<b>17 100</b>	24 000	<b>5 400</b>	4 800	5 600
2312K	H2312	55	2.1654	130	5.1181	46	1.8110	2.0	.079	.33	1.9	3	2	87 100	<b>19 600</b>	28 500	<b>6 410</b>	4 500	5 300
2313K	H2313	60	2.3622	140	5.5118	48	1.8898	2.0	.079	.37	1.7	2.6	1.8	95 600	<b>21 500</b>	32 500	<b>7 310</b>	4 000	4 800
2315K	H2315	65	2.5591	160	6.2992	55	2.1654	2.0	.079	.37	1.7	2.6	1.8	124 000	<b>27 900</b>	43 000	<b>9 670</b>	3 400	4 000
2316K	H2316	70	2.7559	170	6.6929	58	2.2835	2.0	.079	.37	1.7	2.6	1.8	135 000	<b>30 400</b>	49 000	<b>11 000</b>	3 200	3 800
2317K	H2317	75	2.9528	180	7.0866	60	2.3622	2.5	.098	.37	1.7	2.6	1.8	140 000	<b>31 500</b>	51 000	<b>11 500</b>	3 000	3 600
2318K	H2318	80	3.1496	190	7.4803	64	2.5197	2.5	.098	.37	1.7	2.6	1.8	153 000	<b>34 400</b>	57 000	<b>12 800</b>	2 800	3 400
2319K	H2319	85	3.3465	200	7.8740	67	2.6378	2.5	.098	.37	1.7	2.6	1.8	165 000	<b>37 100</b>	64 000	<b>14 400</b>	2 600	3 200
2320K	H2320	90	3.5433	215	8.4646	73	2.8740	2.5	.098	.37	1.7	2.6	1.8	190 000	<b>42 700</b>	80 000	<b>18 000</b>	2 400	3 000
2322K	H2322	100	3.9370	240	9.4488	80	3.1496	2.5	.098	.37	1.7	2.6	1.8	216 000	<b>48 600</b>	95 000	<b>21 400</b>	2 200	2 800

<sup>1)</sup> Fillet radius indicates maximum fillet radius on shaft or in housing which bearing corner will clear.

<sup>2)</sup> Rating for one million revolutions or 500 hours at 33 1/3 RPM.

2200 and 2300 Self-Aligning Series with Seals,  
and with Seals and Tapered Bore

MRC Bearing Services

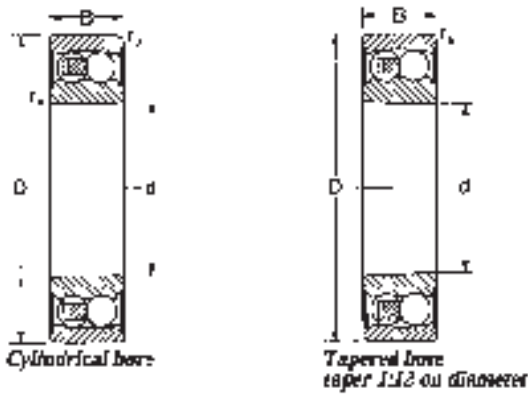

MRC Bearing Number	Bore		Outside Diameter D		Width B		Fillet Radius <sup>1)</sup> r <sub>s</sub>		Calculation Factors				Basic Radial Load Rating				Speed Rating
									e	Y <sub>1</sub>	Y <sub>2</sub>	Y <sub>0</sub>	Dynamic C <sup>2)</sup>		Static C <sub>0</sub>		Grease RPM
	mm	in	mm	in	mm	in	mm	in					N	lbf	N	lbf	
2200E2RS1	10	.3937	30	1.1811	14	.5512	.60	.024	.33	1.9	3	2	5 530	1 240	1 180	265	17 000
2201E2RS1	12	.4724	32	1.2598	14	.5512	.60	.024	.33	1.9	3	2	6 240	1 400	1 430	321	16 000
2202E2RS1	15	.5906	35	1.3780	14	.5512	.60	.024	.33	1.9	3	2	7 410	1 670	1 760	396	14 000
2203E2RS1	17	.6693	40	1.5748	16	.6299	.60	.024	.31	2	3.1	2.2	8 840	1 990	2 200	495	12 000
2204E2RS1	20	.7874	47	1.8504	18	.7087	1.0	.039	.30	2.1	3.3	2.2	12 700	2 860	3 400	764	10 000
2205E2RS1	25	.9843	52	2.0472	18	.7087	1.0	.039	.28	2.2	3.5	2.5	14 300	3 220	4 000	899	9 000
2206E2RS1	30	1.1811	62	2.4409	20	.7874	1.0	.039	.25	2.5	3.9	2.5	15 600	3 510	4 650	1 050	7 500
2207E2RS1	35	1.3780	72	2.8346	23	.9055	1.0	.039	.23	2.7	4.2	2.8	19 000	4 270	6 000	1 350	6 300
2208E2RS1	40	1.5748	80	3.1496	23	.9055	1.0	.039	.22	2.9	4.5	2.8	19 900	4 470	6 950	1 560	5 600
2209E2RS1	45	1.7717	85	3.3465	23	.9055	1.0	.039	.21	3	4.6	3.2	22 900	5 150	7 800	1 750	5 300
22102RS1	50	1.9685	90	3.5433	23	.9055	1.0	.039	.20	3.2	4.9	3.2	22 900	5 150	8 150	1 830	4 800
2211E2RS1	55	2.1654	100	3.9370	25	.9843	1.5	.059	.19	3.3	5.1	3.6	27 600	6 210	10 600	2 380	4 300
2212E2RS1	60	2.3622	110	4.3307	28	1.1024	1.5	.059	.19	3.3	5.1	3.6	31 200	7 010	12 200	2 740	3 800
2213E2RS1	65	2.5591	120	4.7244	31	1.2205	1.5	.059	.18	3.5	5.4	3.6	35 100	7 890	14 000	3 150	3 600
2214E2RS1	70	2.7559	125	4.9213	31	1.2205	1.5	.059	.18	3.5	5.4	3.6	34 500	7 760	13 700	3 080	3 400
2302E2RS1	15	.5906	42	1.6535	17	.6693	1.0	.039	.31	2	3.1	2.2	10 800	2 430	2 600	585	12 000
2303E2RS1	17	.6693	47	1.8504	19	.7480	1.0	.039	.30	2.1	3.3	2.2	12 700	2 860	3 400	764	11 000
2304E2RS1	20	.7874	52	2.0472	21	.8268	1.0	.039	.28	2.2	3.5	2.5	14 300	3 220	4 000	899	9 500
2305E2RS1	25	.9843	62	2.4409	24	.9449	1.0	.039	.28	2.2	3.5	2.5	19 000	4 270	5 400	1 210	7 500
2306E2RS1	30	1.1811	72	2.8346	27	1.0630	1.0	.039	.25	2.5	3.9	2.5	22 500	5 060	6 800	1 530	6 700
2307E2RS1	35	1.3780	80	3.1496	31	1.2205	1.5	.059	.25	2.5	3.9	2.5	26 500	5 960	8 500	1 910	5 600
2308E2RS1	40	1.5748	90	3.5433	33	1.2992	1.5	.059	.23	2.7	4.2	2.8	33 800	7 600	11 200	2 520	5 000
2309E2RS1	45	1.7717	100	3.9370	36	1.4173	1.5	.059	.23	2.7	4.2	2.8	39 000	8 770	13 400	3 010	4 500
2310E2RS1	50	1.9685	110	4.3307	40	1.5748	2.0	.079	.24	2.6	4.1	2.8	43 600	9 800	14 000	3 150	4 000

Tapered Bore

2205E2RS1K	25	.9843	52	2.0472	18	.7087	1.0	.039	.28	2.2	3.5	2.5	14 300	3 220	4 000	899	9 000
2206E2RS1K	30	1.1811	62	2.4409	20	.7874	1.0	.039	.25	2.5	3.9	2.5	15 600	3 510	4 650	1 050	7 500
2207E2RS1K	35	1.3780	72	2.8346	23	.9055	1.0	.039	.23	2.7	4.2	2.8	19 000	4 270	6 000	1 350	6 300
2208E2RS1K	40	1.5748	80	3.1496	23	.9055	1.0	.039	.22	2.9	4.5	2.8	19 900	4 470	6 950	1 560	5 600
2209E2RS1K	45	1.7717	85	3.3465	23	.9055	1.0	.039	.21	3	4.6	3.2	22 900	5 150	7 800	1 750	5 300
22102RS1K	50	1.9685	90	3.5433	23	.9055	1.0	.039	.20	3.2	4.9	3.2	22 900	5 150	8 150	1 830	4 800
2211E2RS1K	55	2.1654	100	3.9370	25	.9843	1.5	.059	.19	3.3	5.1	3.6	27 600	6 210	10 600	2 380	4 300

<sup>1)</sup> Fillet radius indicates maximum fillet radius on shaft or in housing which bearing corner will clear.

<sup>2)</sup> Rating for one million revolutions or 500 hours at 33 1/3 RPM.

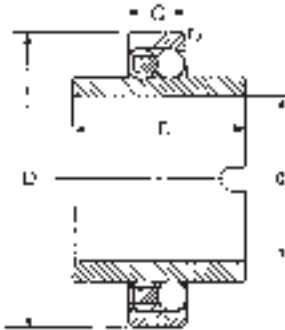

MRC Bearing Number	Bore		Outside Diameter D		Width				Fillet Radius <sup>1)</sup>		Calculation Factors				Basic Radial Load Rating				Speed Rating
					C		B				e	Y <sub>1</sub>	Y <sub>2</sub>	Y <sub>0</sub>	Dynamic C <sub>2</sub> <sup>2)</sup>		Static C <sub>0</sub>		Grease or Oil
	d	mm	in	mm	in	mm	in	mm	in	mm	in					N	lbf	N	lbf
11204E	20	.7874	47	1.8504	14	.5512	40	1.575	1.0	.039	.30	2.1	3.3	2.2	12 700	<b>2 860</b>	3 400	<b>764</b>	9 000
11205E	25	.9843	52	2.0472	15	.5906	44	1.732	1.0	.039	.28	2.2	3.5	2.5	14 300	<b>3 220</b>	4 000	<b>899</b>	8 000
11206E	30	1.1811	62	2.4409	16	.6299	48	1.890	1.0	.039	.25	2.5	3.9	2.5	15 600	<b>3 510</b>	4 650	<b>1 050</b>	6 700
11207E	35	1.3780	72	2.8346	17	.6693	52	2.047	1.0	.039	.23	2.7	4.2	2.8	19 000	<b>4 270</b>	6 000	<b>1 350</b>	5 600
11208E	40	1.5748	80	3.1496	18	.7087	56	2.205	1.0	.039	.22	2.9	4.5	2.8	19 900	<b>4 470</b>	6 950	<b>1 560</b>	5 000
11209E	45	1.7717	85	3.3465	19	.7480	58	2.283	1.0	.039	.21	3	4.6	3.2	22 900	<b>5 150</b>	7 800	<b>1 750</b>	4 500
11210E	50	1.9685	90	3.5433	20	.7874	58	2.283	1.0	.039	.21	3	4.6	3.2	26 500	<b>5 960</b>	9 150	<b>2 060</b>	4 300
11212E	60	2.3622	110	4.3307	22	.8661	62	2.441	1.5	.059	.19	3.3	5.1	3.6	31 200	<b>7 010</b>	12 200	<b>2 740</b>	3 400
11305E	25	.9843	62	2.4409	17	.6693	48	1.890	1.0	.039	.28	2.2	3.5	2.5	19 000	<b>4 270</b>	5 400	<b>1 210</b>	6 700
11306E	30	1.1811	72	2.8346	19	.7480	52	2.047	1.0	.039	.25	2.5	3.9	2.5	22 500	<b>5 060</b>	6 800	<b>1 530</b>	5 600
11307E	35	1.3780	80	3.1496	21	.8268	56	2.205	1.5	.059	.25	2.5	3.9	2.5	26 500	<b>5 960</b>	8 500	<b>1 910</b>	5 000
11308E	40	1.5748	90	3.5433	23	.9055	58	2.283	1.5	.059	.23	2.7	4.2	2.8	33 800	<b>7 600</b>	11 200	<b>2 520</b>	4 500
11310E	50	1.9685	110	4.3307	27	1.0630	62	2.441	2.0	.079	.24	2.6	4.1	2.8	43 600	<b>9 800</b>	14 000	<b>3 150</b>	3 600

<sup>1)</sup> Fillet radius indicates maximum fillet radius on shaft or in housing which bearing corner will clear.

<sup>2)</sup> Rating for one million revolutions or 500 hours at 33 1/3 RPM.

**Bearings with Cylindrical Bore**

Bore Diameter d		C2				Normal				C3				C4					
Over		Including		.001 mm		.0001 in		.001 mm		.0001 in		.001 mm		.0001 in		.001 mm		.0001 in	
mm	in	mm	in	Min	Max	Min	Max	Min	Max	Min	Max	Min	Max	Min	Max	Min	Max	Min	Max
2.5	.0984	6	.2362	1	8	0	3	5	15	2	6	10	20	4	8	15	25	6	10
6	.2362	10	.3937	2	9	1	4	6	17	2	7	12	25	5	10	19	33	7	13
10	.3937	14	.5512	2	10	1	4	6	19	2	7	13	26	5	10	21	35	8	14
14	.5512	18	.7087	3	12	1	5	8	21	3	8	15	28	6	11	23	37	9	15
18	.7087	24	.9449	4	14	2	6	10	23	4	9	17	30	7	12	25	39	10	15
24	.9449	30	1.1811	5	16	2	6	11	24	4	9	19	35	7	14	29	46	11	18
30	1.1811	40	1.5748	6	18	2	7	13	29	5	11	23	40	9	16	34	53	13	21
40	1.5748	50	1.9685	6	19	2	7	14	31	6	12	25	44	10	17	37	57	15	22
50	1.9685	65	2.5591	7	21	3	8	16	36	6	14	30	50	12	20	45	69	18	27
65	2.5591	80	3.1496	8	24	3	9	18	40	7	16	35	60	14	24	54	83	21	33
80	3.1496	100	3.9370	9	27	4	11	22	48	9	19	42	70	17	28	64	96	25	38
100	3.9370	120	4.7244	10	31	4	12	25	56	10	22	50	83	20	33	75	114	30	45
120	4.7244	140	5.5118	10	38	4	15	30	68	12	27	60	100	24	39	90	135	35	53

**Bearings with Tapered Bore**

18	.7087	24	.9449	7	17	3	7	13	26	5	10	20	33	8	13	28	42	11	17
24	.9449	30	1.1811	9	20	4	8	15	28	6	11	23	39	9	15	33	50	13	20
30	1.1811	40	1.5748	12	24	5	9	19	35	7	14	26	46	10	18	40	59	16	23
40	1.5748	50	1.9685	14	27	6	11	22	39	9	15	33	52	13	20	45	65	18	26
50	1.9685	65	2.5591	18	32	7	13	27	47	11	19	41	61	16	24	56	80	22	31
65	2.5591	80	3.1496	23	39	9	15	35	57	14	22	50	75	20	30	69	98	27	39
80	3.1496	100	3.9370	29	47	11	19	42	68	17	27	62	90	24	35	84	116	33	46
100	3.9370	120	4.7244	35	56	14	22	50	81	20	32	75	108	30	43	100	139	39	55

**Allowable Angular Misalignment of Self-Aligning Ball Bearings**

Bearing Series	Allowable Angular Misalignment Degrees
108, 126, 127, 129, 135	3
1200, 1200E	2.5
1300, 1300E	3
1400	3
2200, 2200E	2.5
2200ERS1	1.5
2300, 2300E	3
2300ERS1	1.5
11200E	2.5
11300E	3

### Dynamic and static equivalent radial load and life rating

#### Dynamic equivalent radial load

$$P = F_R + Y_1 F_A, \text{ where } F_A/F_R \leq e$$

or

$$P = 0.65 F_R + Y_2 F_A, \text{ where } F_A/F_R > e$$

$P$  = Dynamic equivalent radial load  
 $F_R$  = Radial load  
 $F_A$  = Thrust load  
 $Y_1$  = Thrust load factor  
 $Y_2$  = Thrust load factor  
 $e$  = Limiting factor for  $F_A/F_R$

$Y_1$ ,  $Y_2$  and  $e$  are given in bearing tables

#### Life rating

$$L_{10} = \left(\frac{C}{P}\right)^3 \text{ (millions of revolutions)}$$

or

$$L_{10h} = \frac{10^6}{60n} \left(\frac{C}{P}\right)^3 \text{ (Hours)}$$

$C$  = Basic dynamic load rating  
 $P$  = Dynamic equivalent radial load  
 $n$  = Speed in RPM

#### Static equivalent radial load

$$P_0 = F_R + Y_0 F_A$$

$P_0$  = Static equivalent radial load  
 $F_R$  = Radial load  
 $F_A$  = Thrust load  
 $Y_0$  = Thrust load factor  
 $Y_0$  given in bearing tables

### Dynamic equivalent radial load and life calculation examples

Bearing size: 1209E  
 Speed: 2000 RPM  
 Basic dynamic radial load rating ( $C$ ) = 5150  
 $e = 0.21$   
 $Y_1 = 3.0$   
 $Y_2 = 4.6$

#### Case 1

Radial load ( $F_R$ ) = 500  
 Thrust load ( $F_A$ ) = 100  
 $F_A/F_R = 100/500 = 0.20$   
 Equivalent load ( $P$ ) =  $F_R + Y_1 F_A$   
 $P = 500 + 3.0 \times 100 = 800$

$L_{10} = \left(\frac{C}{P}\right)^3 = \left(\frac{5150}{800}\right)^3 = 266.8 \times 10^6 \text{ Rev.}$   
 or  
 $L_{10h} = \frac{10^6}{60n} \left(\frac{C}{P}\right)^3 = \frac{10^6}{60 \times 2000} \left(\frac{5150}{800}\right)^3$   
 $= 2223 \text{ Hrs}$

#### Case 2

Radial load ( $F_R$ ) = 500  
 Thrust load ( $F_A$ ) = 170  
 $F_A/F_R = 170/500 = 0.34$   
 Equivalent load ( $P$ ) =  $0.65 F_R + Y_2 F_A$   
 $P = 0.65 \times 500 + 4.6 \times 170 = 1107$

$L_{10} = \left(\frac{C}{P}\right)^3 = \left(\frac{5150}{1107}\right)^3 = 100.7 \times 10^6 \text{ Rev.}$   
 or  
 $L_{10h} = \frac{10^6}{60n} \left(\frac{C}{P}\right)^3 = \frac{10^6}{60 \times 2000} \left(\frac{5150}{1107}\right)^3$   
 $= 839 \text{ Hrs}$

#### Minimum load

In order to provide satisfactory operation, self-aligning ball bearings, like all ball and roller bearings, must always be subjected to a given minimum load, particularly if they are to operate at high speeds or are subjected to high accelerations or rapid changes in the direction of load. Under such conditions the inertia forces of the balls and cage, and the friction in the lubricant, can have a detrimental influence on the rolling conditions in the bearing arrangement and may cause damaging sliding movements to occur between the balls and raceways.

The requisite minimum load to be applied to self-aligning ball bearings can be estimated using

$$P_{0m} = 0,01 C_0$$

where

$P_{0m}$  = minimum equivalent static bearing load, lbs  
 $C_0$  = basic static load rating, lbs

When starting up at low temperatures or when the lubricant is highly viscous, even greater minimum loads may be required. The weight of the components supported by the bearing, together with external forces, generally exceeds the requisite minimum load. If this is not the case, the self-aligning ball bearing must be subjected to an additional radial load, for example, by increasing belt tension or by similar means.



### Ball Protrusion

Self-aligning bearings in Series 1400 and in some sizes in Series 1200, 1200K and 1300K, have ball protrusion beyond the bearing ring faces as shown in the table below. This must be considered when designing adjacent components.

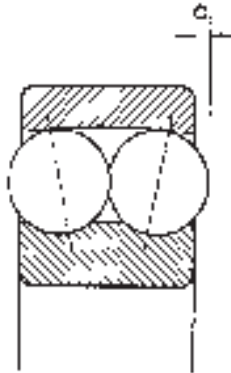

### Axial load carrying capacity of bearings mounted on adapter sleeves

The ability of self-aligning ball bearings mounted on adapter sleeves on smooth shafts to carry axial loads, depends on the friction between sleeve and shaft. The approximate permissible axial load can be determined from

$$F_{AP} = 3 B d$$

where,  $F_{AP}$  = maximum permissible axial load (N)  
 $B$  = bearing width (mm)  
 $d$  = bearing bore (mm)

to convert newtons (N) to pounds multiply by 0.2248

Size	Protrusion (C <sub>1</sub> )	
	mm	inches
1224K	1.3	.051
1226	0.7	.028
1318K	1.0	.039
1319K	1.5	.059
1320K	2.5	.098
1321K	2.6	.102
1322K	2.6	.102
1406	2.2	.087
1407	2.0	.079
1408	2.0	.079
1409	2.5	.098
1410	3.0	.118
1411	2.4	.094
1412	2.8	.110

## Mounting bearings with tapered bore

Bearings with a tapered bore are always mounted with an interference fit on the shaft, adapter sleeve or withdrawal sleeve. As a measure of the  $^{\circ}$  of interference of the fit, either the reduction in radial internal clearance of the bearing or the axial displacement of the inner ring on the tapered bearing seating can be used. The mounting of self-aligning ball bearings with tapered bore calls for experience and skill as they have a relatively small internal clearance, and a reliable measurement of the clearance reduction is not always possible.

When mounting bearings with Normal radial internal clearance it is generally sufficient to check clearance reduction during the drive-up by turning and swivelling out the outer ring. When the bearing is properly mounted the outer ring can be easily turned but there should be a slight resistance when the ring is swivelled out. The bearing will then have the requisite interference fit. In some cases, however, the residual internal clearance may be too small for the application, and a bearing with C3 radial internal clearance should be used instead.

When mounting bearings with C3 clearance, the tightening angle  $\alpha$  or the axial displacement  $S$  can be used to measure the  $^{\circ}$  of interference. The procedures and values given in the following also

apply to bearings with Normal clearance.

An easy method of mounting bearings on adapter sleeves is based on the tightening angle  $\alpha$  through which the nut is turned and the procedure is described in the following. Guideline values for the tightening angle  $\alpha$  are given in the table overleaf. Before mounting, the thread of the nut and the side face of the nut which is to abut the bearing should be smeared with a molybdenum disulphide paste or similar lubricant, and the outside diameter of the sleeve should be lightly oiled. The bearing is then pushed on to the sleeve and the nut screwed on. By turning the nut through the given angle  $\alpha$  the bearing will be pressed up on the tapered seating of the sleeve. As the bearing has a tendency to skew when being pressed up it is advisable to reposition the hook spanner in a slot at  $180^{\circ}$  to that used for tightening and then apply a light hammer blow to the spanner. The bearing will straighten up on its seating. The nut is then removed, the locking washer inserted and the nut replaced, tightened and locked by bending down one of the tabs of the locking washer. The residual clearance of the bearing should be checked.

Another method which is often used to mount bearings with a tapered bore correctly and reliably is to measure the axial displacement  $S$  of the inner ring on the tapered

seating. Guideline values for the requisite displacement  $S$  are given in the table overleaf.

When using either of the above methods, the self-aligning ball bearings should always be pushed up on to the tapered seating until the bore of the bearing is in contact with the seating on the shaft or sleeve around its whole circumference, before the final tightening procedure is begun. A sufficiently tight fit will then be obtained and the residual clearance will correspond to the mean values given in the table.

One method of measuring the internal clearance of self-aligning ball bearings is shown in the illustrations below. A washer A is inserted between the bearing and the shaft or sleeve nut to ensure correct alignment of the outer ring with respect to the inner ring. A dial gauge B placed on the bearing outer ring can be used to measure the bearing clearance. The outer ring should be pushed upwards in the direction of the shaft.

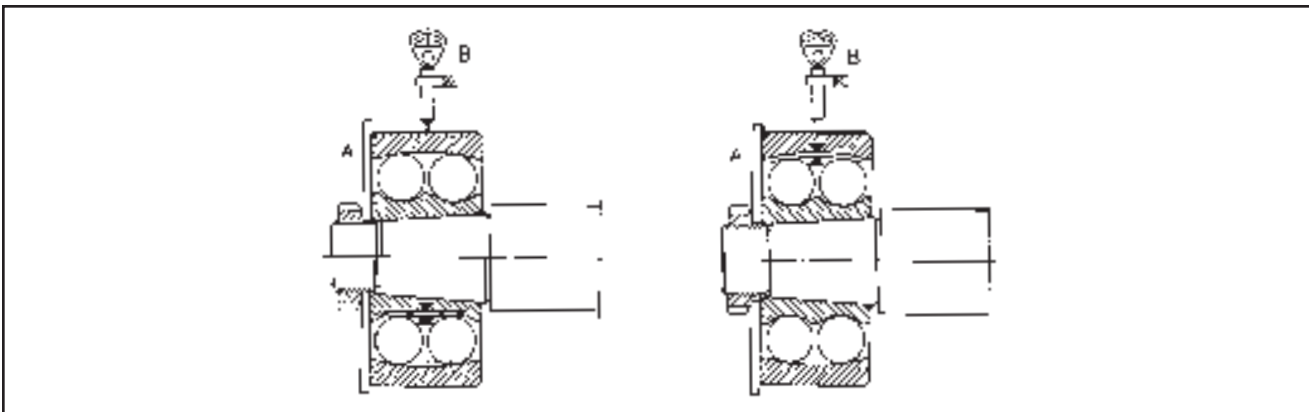



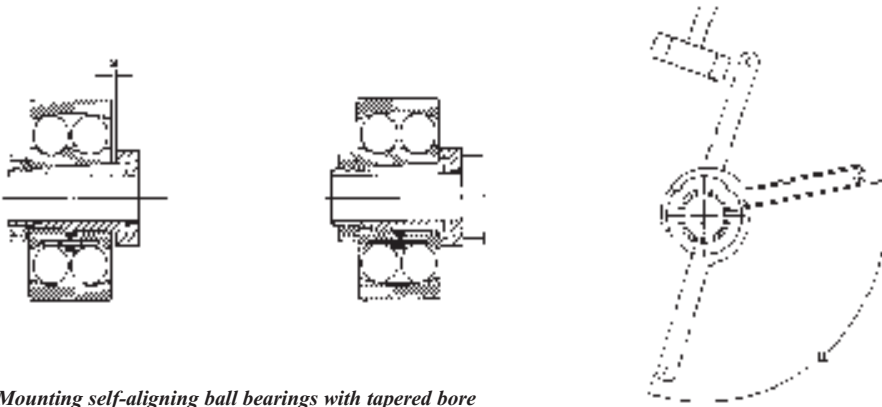

Mounting self-aligning ball bearings with tapered bore

Bearing Bore d		Tightening Angle $\alpha$ Degrees	Axial Displacement S								Mean Residual Clearance After Mounting			
			Bearing Series								Normal		C3	
			1200K		1300K		2200K		2300K		.001 mm	.0001 in	.001 mm	.0001 in
mm	in	mm	in	mm	in	mm	in	mm	in	mm	in	mm	in	
20	.7874	70	.22	.009	.23	.009	—	—	—	10	4	20	8	
25	.9843	70	.22	.009	.23	.009	.22	.009	.23	.009	10	4	20	8
30	1.1811	70	.22	.009	.23	.009	.22	.009	.23	.009	10	4	20	8
35	1.3780	70	.30	.012	.30	.012	.30	.012	.30	.012	10	4	20	8
40	1.5748	70	.30	.012	.30	.012	.30	.012	.30	.012	10	4	20	8
45	1.7717	70	.31	.012	.34	.013	.31	.012	.33	.013	15	6	25	10
50	1.9685	70	.31	.012	.34	.013	.31	.012	.33	.013	15	6	25	10
55	2.1654	90	.40	.016	.41	.016	.39	.015	.40	.016	15	6	30	12
60	2.3622	90	.40	.016	.41	.016	.39	.015	.40	.016	15	6	30	12
65	2.5591	90	.40	.016	.41	.016	.39	.015	.40	.016	15	6	30	12
75	2.9528	120	.45	.018	.47	.019	.43	.017	.46	.018	20	8	40	16
80	3.1496	120	.45	.018	.47	.019	.43	.017	.46	.018	20	8	40	16
85	3.3465	120	.58	.023	.60	.024	.54	.021	.59	.023	20	8	40	16
90	3.5433	120	.58	.023	.60	.024	.54	.021	.59	.023	20	8	40	16
95	3.7402	120	.58	.023	.60	.024	.54	.021	.59	.023	20	8	40	16
100	3.9370	120	.58	.023	.60	.024	.54	.021	.59	.023	20	8	40	16
105	4.1339	120	.67	.026	—	—	.66	.026	—	—	25	10	55	22
110	4.3307	120	.67	.026	.70	.028	.66	.026	.69	.027	25	10	55	22
120	4.7244	120	.67	.026	—	—	—	—	—	—	25	10	55	22