



Right Hand Worm and Gear



Single, Double, Quadruple Thread Worms

***NOTE: SELF-LOCKING ABILITY**

There is often some confusion as to the self-locking ability of a worm and gear set. *Martin* worm gear sets, under no condition should be considered to hold a load when at rest. The statement is made to cover the broad spectrum of variables affecting self-locking characteristics of a particular gear set in a specific application. Theoretically, a worm gear will not back drive if the friction angle is greater than the worm lead angle. However, the actual surface finish and lubrication may reduce this significantly. More important, vibration may cause motion at the point of mesh with further reduction in the friction angle.

Generally speaking, if the worm lead angle is less than 5°, there is reasonable expectation of self-locking. Again, no guarantee should be made and customer should be advised. **If safety is involved, a positive brake should be used.**

Originally, worm gearing was used to secure, by compact means, a large reduction of speed between driving and driven shafts with a proportionate increase (except for frictional loss) in the torque of the driven shaft. Worm gearing is still used for this purpose, and frequently the wheel is driven by a single-thread worm of such low helix angle that the drive cannot be reversed; that is the wheel cannot drive the worm as the gearing automatically locks itself against backward rotation. (*See note below.)

Although a multiple-threaded worm when applied under like conditions is much more efficient than a single-threaded worm, it does not follow that the multiple-threaded worm should always be used.

A single-threaded worm might be preferable when the most important requirement is to obtain a high ratio and especially if the worm must be self-locking.

When power is the primary factor, the multiple-threaded worms should be used.

LUBRICATION is an important factor when using worm gearing. An increase in heat generated means a decrease in efficiency. The amount of power which can be transmitted at a given temperature increases as the efficiency of the gearing increases.

MATERIALS for worm and worm gears are generally confined to steel for worms and bronze or cast iron for gears. When steel worms are run with bronze gears at high speeds, the worm is usually hardened with ground threads.

GEARS

Direction of Rotation and Thrust Right Hand

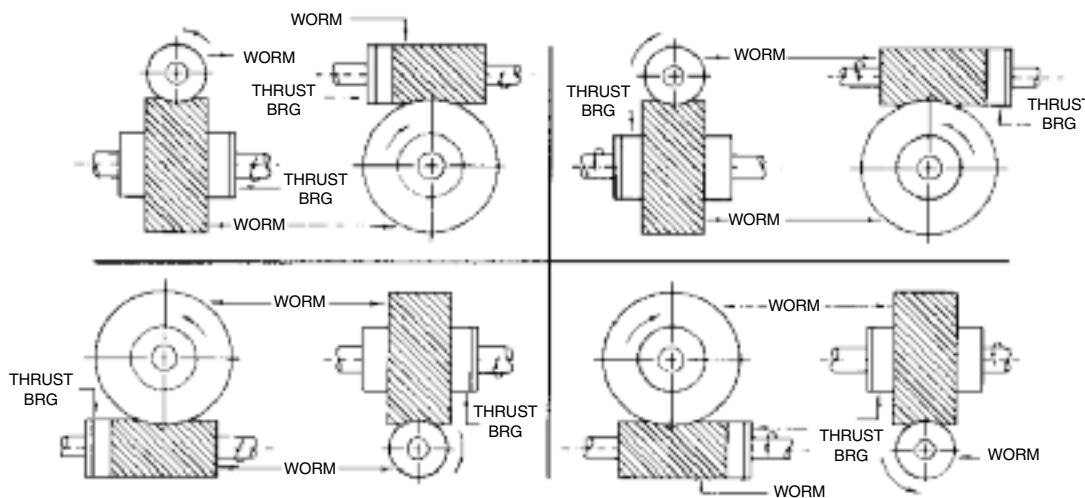

Worm and Worm Gears

3 Pitch • 2" Face • 14½° Pressure Angle

Martin

Right Hand Single Thread (Stocked Right Hand Only)

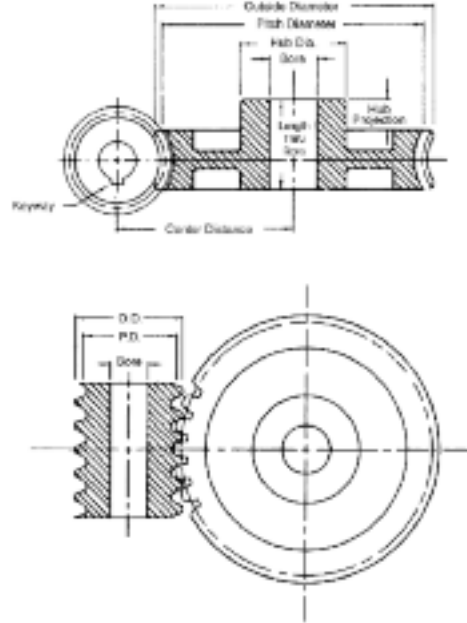

GEARS

Cast Iron

No. Teeth	Catalog Number Cast Iron	Wt. Lbs. (App.)	Pitch Dia.	Bore (Inches)	Hub (Inches)		Style
					Dia.	Proj.	
18	W318	16.2	6.000	1	3	1½	W
24	W324	22.8	8.000	1½	3½	1½	S
30	W330	30.2	10.000	1½	3½	1½	S
36	W336	36.4	12.000	1½	3½	1½	S
54	W354	60.2	18.000	1½	4	1½	S

W = WEB S = SPOKE



Steel — 4° 46' Helix Angle Worms

Catalog Number Soft	Wt. Lbs. (App.)	Catalog Number Hardened	Wt. Lbs. (App.)	Faces (Inches)	Pitch Dia.	Bore (Inches)	Keyway (Inches)
W3	12.2	WG3	12.0	4	4.000	1½	⅜x⅜

Case hardened worms have ground and polished threads (Indicated by letter "G" in catalog number). Please Note: Stock Bore sizes on ground worms may be difficult to modify.

Right Hand Single Thread (Stocked Right Hand Only)

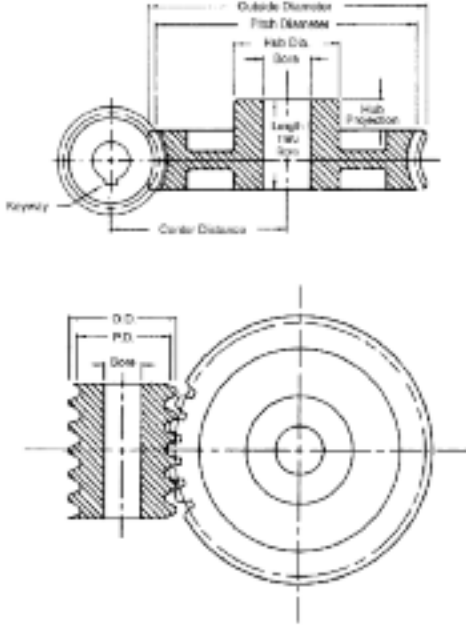

Cast Iron

No. Teeth	Catalog Number Cast Iron	Wt. Lbs. (App.)	Pitch Dia.	Bore (Inches)	Hub (Inches)		Style
					Dia.	Proj.	
20	W420	8.4	5.000	1	2½	1¼	W
24	W424	12.9	6.000	1	2½	1¼	W
32	W432	15.6	8.000	1¼	3	1¼	W
40	W440	27.5	10.000	1¼	3	1¼	W
48	W448	34.1	12.000	1½	4	1¼	W
64	W464	43.9	16.000	1½	4	1¼	S

W = WEB S = SPOKE



Steel — 4° 46' Helix Angle Worms

Catalog Number Soft	Wt. Lbs. (App.)	Catalog Number Hardened	Wt. Lbs. (App.)	Faces (Inches)	Pitch Dia.	Bore (Inches)	Keyway (Inches)
W4	5.6	WG4	5.5	3½	3.000	1¼	⅝x⅜

Case hardened worms have ground and polished threads (Indicated by letter "G" in catalog number).
Please Note: Stock Bore sizes on ground worms may be difficult to modify.

Worm and Worm Gears

6 Pitch • 1" Face • 14½° Pressure Angle

Right Hand Single Thread (Stocked Right Hand Only)

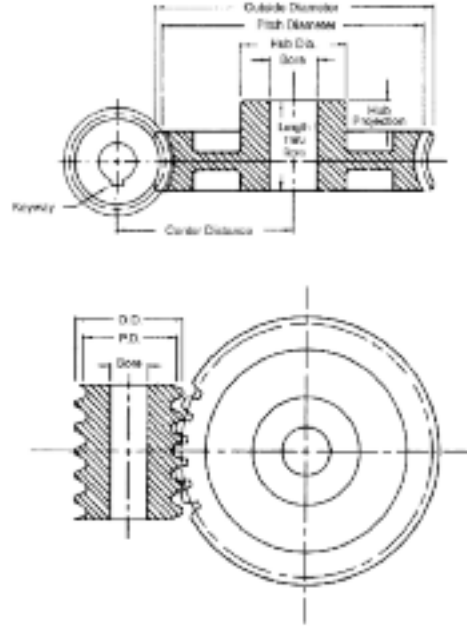

GEARS

Cast Iron

No. Teeth	Catalog Number Cast Iron	Wt. Lbs. (App.)	Pitch Dia.	Bore (Inches)	Hub (Inches)		Style
					Dia.	Proj.	
20	W620	2.5	3.333	¾	1½	¾	W
24	W624	3.6	4.000	¾	1½	¾	W
30	W630	5.0	5.000	¾	2¼	¾	W
36	W636	6.0	6.000	1	2½	¾	W
40	W640	7.6	6.667	1	2½	¾	W
48	W648	9.2	8.000	1¼	2¾	1	W
60	W660	13.7	10.000	1¼	3	1¼	W
72	W672	14.9	12.000	1¼	3	1¼	W

Has 2¼" hub diameter and 1¼" hub proj. W = WEB



Steel — 4° 46' Helix Angle Worms

Catalog Number Soft	Wt. Lbs. (App.)	Catalog Number Hardened	Wt. Lbs. (App.)	Face (Inches)	Pitch Dia.	Bore (Inches)	Hub (Inches)		Keyway (Inches)
							Dia.	Proj.	
W6	1.8	WG6	1.7	2½	2.000	¾	1⅙	¾	⅜x⅜
WH6	2.7			2½	2.000	¾	1⅙	¾	⅜x⅜

Case hardened worms have ground and polished threads (Indicated by letter "G" in catalog number).

Please Note: Stock Bore sizes on ground worms may be difficult to modify.

G-60

Right Hand Double Thread (Stocked Right Hand Only)

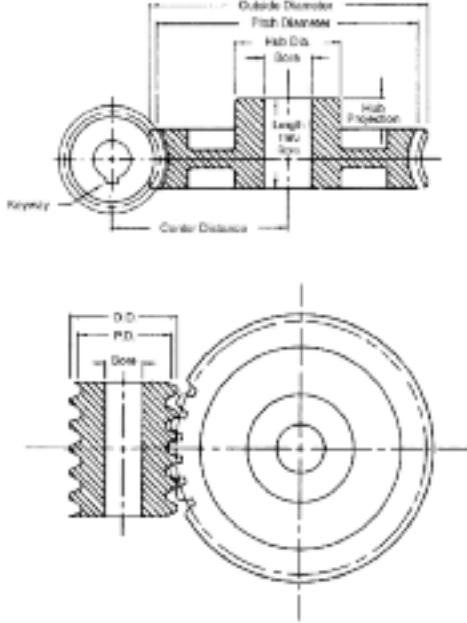

Cast Iron

Number Teeth	Catalog Number Cast Iron	Wt. Lbs. (App.)	Pitch Dia.	Bore (Inches)	Hub (Inches)		Style
					Dia.	Proj.	
20	W620D	3.3	3.333	1	2½	1	PLAIN
24	W624D	4.1	4.000	1¼	2½	1	PLAIN
30	W630D	5.2	5.000	1¼	2½	1	W
40	W640D	7.6	6.667	1¼	2½	1	W

W = WEB



Steel — 9° 28' Helix Angle Worms

Catalog Number Soft	Weight Pounds (App.)	Face (Inches)	Pitch Diameter	Bore (Inches)	Keyway (Inches)
W6D	1.6	2½	2.000	1	¼x¼

Worm and Worm Gears

6 Pitch • 1" Face • 14½° Pressure Angle



Right Hand Quadruple Thread (Stocked Right Hand Only)

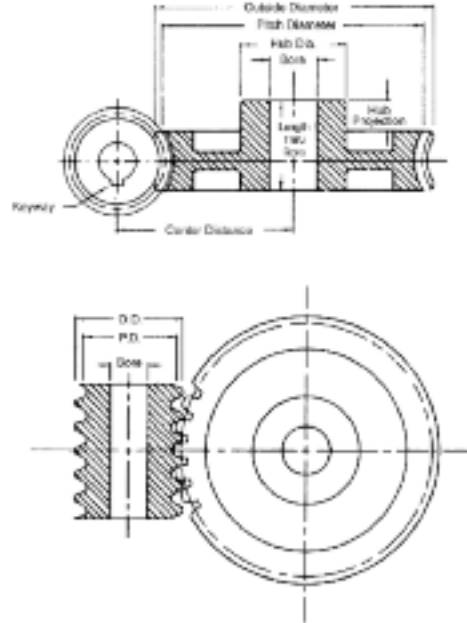

GEARS

Cast Iron

Number Teeth	Catalog Number Cast Iron	Wt. Lbs. (App.)	Pitch Dia.	Bore (Inches)	Hub (Inches)		Style
					Dia.	Proj.	
20	W620Q	3.4	3.333	1	2½	1	PLAIN
24	W624Q	4.1	4.000	1¼	2½	1	PLAIN



Steel — 18° 26' Helix Angle Worms

Catalog Number Soft	Wt. Lbs. (App.)	Face (Inches)	Pitch Diameter	Bore (Inches)	Keyway (Inches)
W6Q	1.6	2½	2.000	1	¼X¼

Right Hand Single Thread (Stocked Right Hand Only)

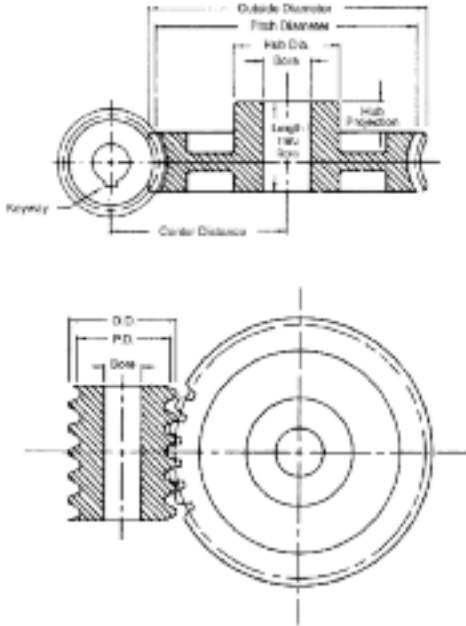

Cast Iron

Number Teeth	Catalog Number Cast Iron	Weight Pounds (App.)	Pitch Dia.	Bore (Inches)	Hub (Inches)		Style
					Dia.	Proj.	
20	W820	1.3	2.500	$\frac{3}{4}$	$1\frac{1}{4}$	$\frac{3}{4}$	PLAIN
30	W830	2.4	3.750	$\frac{3}{4}$	$1\frac{1}{4}$	$\frac{3}{4}$	W
40	W840	3.7	5.000	1	$2\frac{3}{8}$	$\frac{7}{8}$	W
48	W848	4.5	6.000	1	$2\frac{3}{8}$	$\frac{7}{8}$	W
50	W850	5.1	6.250	1	$2\frac{3}{8}$	$\frac{7}{8}$	W
60	W860	6.1	7.500	1	$2\frac{1}{2}$	$\frac{7}{8}$	W
80	W880	8.9	10.000	$1\frac{1}{4}$	3	$\frac{7}{8}$	W

W = WEB



Steel — $4^\circ 46'$ Helix Angle Worms

Catalog Number Soft	Weight Pounds (App.)	Catalog Number Hardened	Wt. Lbs. (App.)	Face (Inches)	Pitch Dia.	Bore (Inches)	Hub (Inches)		Keyway (Inches)
							Dia.	Proj.	
W8	.64	WG8	.62	$1\frac{1}{4}$	1.500	$\frac{3}{4}$	$1\frac{1}{6}$	$\frac{5}{8}$	$\frac{3}{16} \times \frac{3}{16}$
WH8	.74			$1\frac{1}{4}$	1.500	$\frac{3}{4}$	$1\frac{1}{6}$	$\frac{5}{8}$	

Case hardened worms have ground and polished threads (Indicated by letter "G" in catalog number).
Please Note: Stock Bore sizes on ground worms may be difficult to modify.

Worm and Worm Gears

8 Pitch • $\frac{3}{4}$ " Face • $14\frac{1}{2}^\circ$ Pressure Angle



Right Hand Double Thread (Stocked Right Hand Only)

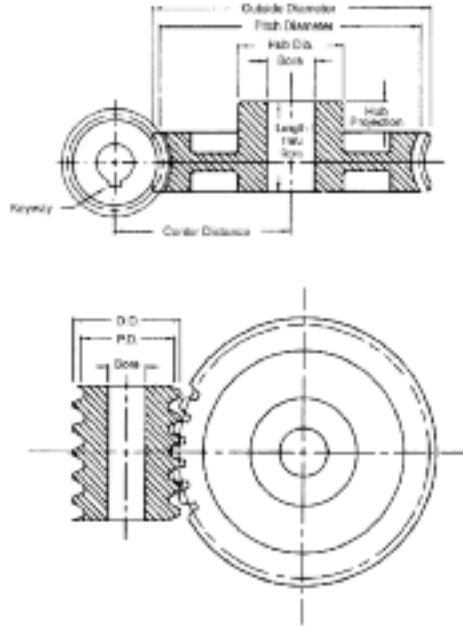

GEARS

Cast Iron

Number Teeth	Catalog Number Cast Iron	Weight Pounds (App.)	Pitch Dia.	Bore (Inches)	Hub (Inches)		Style
					Dia.	Proj.	
20	W820D	1.2	2.500	1	2	$\frac{3}{4}$	PLAIN
30	W830D	2.5	3.750	1	$2\frac{1}{4}$	$\frac{3}{4}$	W
40	W840D	3.4	5.000	1	$2\frac{1}{4}$	$\frac{3}{4}$	W

W = WEB



Steel — $9^\circ 28'$ Helix Angle Worms

Catalog Number Soft	Weight Pounds (App.)	Catalog Number Hardened	Wt. Lbs. (App.)	Face (Inches)	Pitch Dia.	Bore (Inches)	Hub (Inches)		Keyway (Inches)
							Dia.	Proj.	
W8D	.56	WG8D	.54	$1\frac{1}{4}$	1.500	$\frac{7}{8}$			$\frac{3}{16} \times \frac{3}{32}$
WH8D	.74			$1\frac{1}{4}$	1.500	$\frac{7}{8}$	$1\frac{1}{16}$	$\frac{3}{4}$	

Case hardened worms have ground and polished threads (Indicated by letter "G" in catalog number). Please Note: Stock Bore sizes on ground worms may be difficult to modify.



Worm and Worm Gears

8 Pitch • $\frac{3}{4}$ " Face • $14\frac{1}{2}^\circ$ Pressure Angle

Right Hand Quadruple Thread (Stocked Right Hand Only)

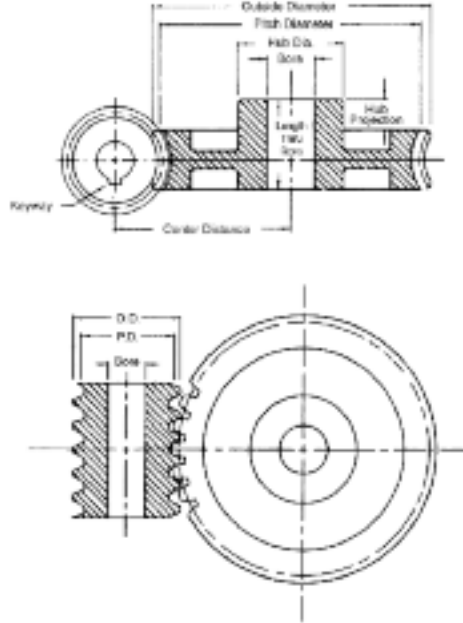

Cast Iron

Number Teeth	Catalog Number Cast Iron	Weight Pounds (App.)	Pitch Dia.	Bore (Inches)	Hub (Inches)		Style
					Dia.	Proj.	
20	W820Q	1.2	2.500	1	2	$\frac{3}{4}$	PLAIN
30	W830Q	2.5	3.750	1	2 $\frac{1}{2}$	$\frac{3}{4}$	W

W = WEB



Steel — $18^\circ 26'$ Helix Angle Worms

Catalog Number Cast Iron	Weight Pounds (App.)	Face (Inches)	Pitch Dia.	Bore (Inches)	Hub (Inches)		Keyway (Inches)
					Dia.	Proj.	
W8Q	.58	$1\frac{1}{4}$	1.500	$\frac{7}{8}$	$1\frac{1}{6}$	$\frac{5}{8}$	$\frac{3}{16} \times \frac{3}{32}$
WH8Q	.76	$1\frac{1}{4}$	1.500	$\frac{7}{8}$	$1\frac{1}{6}$	$\frac{5}{8}$	$\frac{3}{16} \times \frac{3}{32}$

Worm and Worm Gears

10 Pitch • $\frac{5}{8}$ " Face • $14\frac{1}{2}^\circ$ Pressure Angle



Right Hand Single Thread (Stocked Right Hand Only)

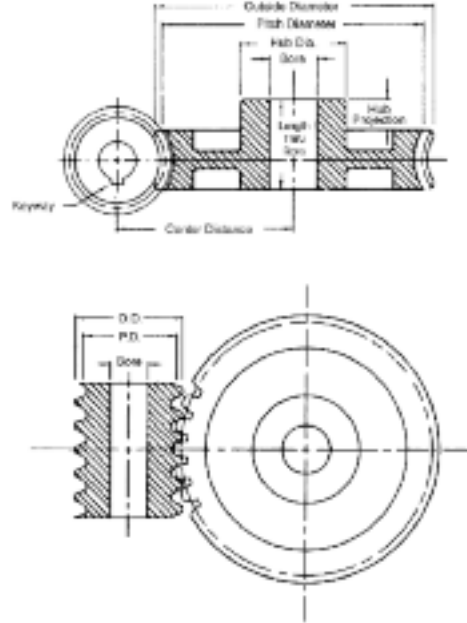

GEARS

Cast Iron and Bronze

Number Teeth	Catalog Number Cast Iron	Weight Pounds (App.)	Pitch Dia.	Bore (Inches)	Hub (Inches)		Style	Catalog Number Bronze	Weight Pounds (App.)
					Dia.	Proj.			
20	W1020	.7	2.000	$\frac{1}{2}$	$1\frac{1}{4}$	$\frac{3}{4}$	PLAIN	WB1020	.8
30	W1030	1.5	3.000	$\frac{5}{8}$	$1\frac{1}{2}$	$\frac{3}{4}$	PLAIN	WB1030	1.7
40	W1040	1.8	4.000	$\frac{5}{8}$	$1\frac{3}{4}$	$\frac{3}{4}$	W	WB1040	2.4
50	W1050	2.8	5.000	$\frac{3}{4}$	2	$\frac{3}{4}$	W		
60	W1060	3.6	6.000	$\frac{3}{4}$	2	$\frac{3}{4}$	W		
80	W1080	4.8	8.000	$\frac{3}{4}$	2	$\frac{3}{4}$	W		
100	W10100	6.0	10.000	$\frac{3}{4}$	$2\frac{1}{2}$	$\frac{3}{4}$	W		

W = WEB



Steel — $4^\circ 34'$ Helix Angle Worms

Catalog Number Soft	Weight Pounds (App.)	Catalog Number Hardened	Weight Pounds (App.)	Face (Inches)	Pitch Dia.	Bore (Inches)	Hub (Inches)		Keyway (Inches)
							Dia.	Proj.	
W10	.36	WG10	.32	$1\frac{1}{8}$	1.250	$\frac{5}{8}$	1	$\frac{1}{2}$	$\frac{3}{16} \times \frac{3}{16}$
WH10	.42		.38	$1\frac{1}{8}$	1.250	$\frac{5}{8}$			

Case hardened worms have ground and polished threads (Indicated by letter "G" in catalog number).
Please Note: Stock Bore sizes on ground worms may be difficult to modify.

Right Hand Double Thread (Stocked Right Hand Only)

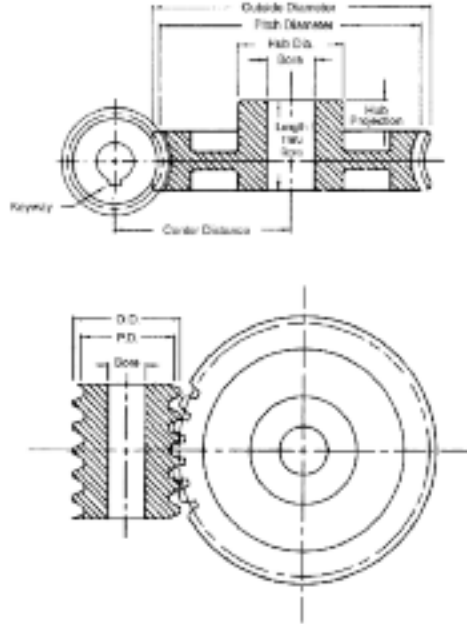

Cast Iron and Bronze

No. Teeth	Catalog Number Cast Iron	Wt. Lbs. (App.)	Pitch Dia.	Bore (Inches)	Hub (Inches)		Style	Catalog Number Bronze	Wt. Lbs. (App.)
					Dia.	Proj.			
20	W1020D	.65	2.000	$\frac{7}{8}$	1 $\frac{1}{2}$	$\frac{5}{8}$	PLAIN	WB1020D	.75
30	W1030D	1.3	3.000	$\frac{7}{8}$	1 $\frac{1}{2}$	$\frac{5}{8}$	PLAIN	WB1030D	1.3
40	W1040D	1.6	4.000	$\frac{7}{8}$	1 $\frac{3}{4}$	$\frac{5}{8}$	W		
50	W1050D	2.9	5.000	$\frac{7}{8}$	2	1	W		
60	W1060D	3.0	6.000	$\frac{7}{8}$	2	1	W		

W = WEB



Steel — $9^\circ 5'$ Helix Angle Worms

Catalog Number Soft	Weight Pounds (App.)	Face (Inches)	Pitch Dia.	Bore (Inches)	Hub (Inches)		Keyway (Inches)
					Dia.	Proj.	
W10D	.28	1 $\frac{1}{2}$	1.2500	$\frac{3}{4}$	1	$\frac{1}{2}$	$\frac{3}{16} \times \frac{1}{32}$
WH10D	.42	1 $\frac{1}{2}$	1.2500	$\frac{3}{4}$	1	$\frac{1}{2}$	$\frac{3}{16} \times \frac{1}{32}$

Worm and Worm Gears

10 Pitch • $\frac{5}{8}$ " Face • $14\frac{1}{2}^\circ$ Pressure Angle



Right Hand Quadruple Thread (Stocked Right Hand Only)

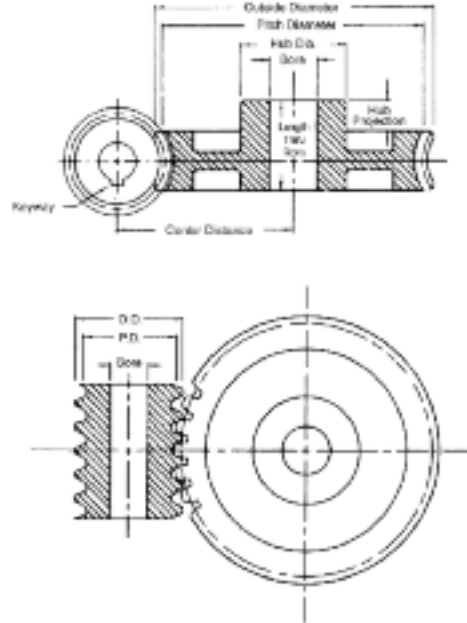

GEARS

Cast Iron

Number Teeth	Catalog Number Cast Iron	Weight Pounds (App.)	Pitch Dia.	Bore (Inches)	Hub (Inches)		Style
					Dia.	Proj.	
20	W1020Q	.64	2.000	$\frac{7}{8}$	1 $\frac{1}{2}$	$\frac{5}{8}$	PLAIN
30	W1030Q	1.3	3.000	$\frac{7}{8}$	1 $\frac{1}{2}$	$\frac{5}{8}$	W
40	W1040Q	1.6	4.000	$\frac{7}{8}$	1 $\frac{1}{2}$	$\frac{5}{8}$	W

W = WEB



Steel — $17^\circ 45'$ Helix Angle Worms

Catalog Number Soft	Weight Pounds (App.)	Face (Inches)	Pitch Dia.	Bore (Inches)	Hub (Inches)		Keyway (Inches)
					Dia.	Proj.	
W10Q	.28	1 $\frac{1}{2}$	1.250	$\frac{3}{4}$	1	$\frac{1}{2}$	$\frac{3}{16} \times \frac{1}{2}$
WH10Q	.40	1 $\frac{1}{2}$	1.250	$\frac{3}{4}$	1	$\frac{1}{2}$	$\frac{3}{16} \times \frac{1}{2}$



Worm and Worm Gears

12 Pitch • 1/2" Face • 14 1/2° Pressure Angle

Right Hand Single Thread (Stocked Right Hand Only)

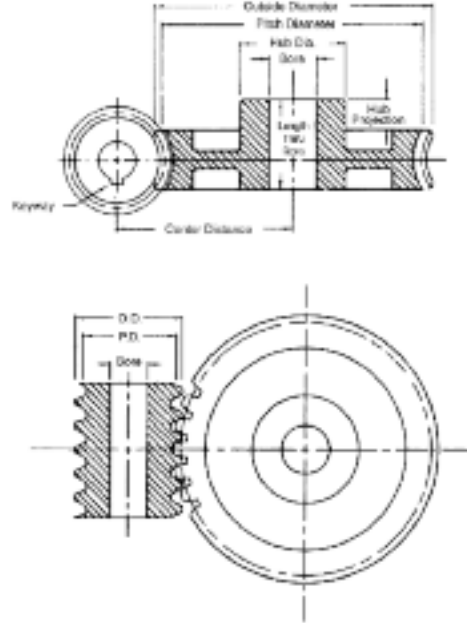

Cast Iron and Bronze

Number Teeth	Catalog Number Cast Iron	Weight Pounds (App.)	Pitch Dia.	Bore (Inches)	Hub (Inches)		Style	Catalog Number Bronze	Wt. Lbs. (App.)
					Dia.	Proj.			
18	W1218	.28	1.500	1/2	1 1/4	5/8	PLAIN	WB1220	.45
20	W1220	.35	1.667	1/2	1 1/4	5/8	PLAIN		
30	W1230	.71	2.500	1/2	1 1/4	5/8	W		
40	W1240	1.2	3.333	5/8	1 1/2	3/4	W		
50	W1250	1.5	4.166	5/8	1 1/2	3/4	W		
60	W1260	2.0	5.000	5/8	1 1/4	3/4	W		
80	W1280	3.9	6.666	5/8	2 1/2	3/4	W		
100	W12100	4.4	8.333	3/4	2	3/4	W		

W = WEB



Steel — 4° 46' Helix Angle Worms

Catalog Number Soft	Weight Pounds (App.)	Catalog Number Hardened	Weight Pounds (App.)	Face (Inches)	Pitch Dia.	Bore (Inches)	Hub (Inches)		Keyway (Inches)
							Dia.	Proj.	
W12	.17	WG12	.14	1 1/2	1.000	1/2			1/8 x 1/8
WH12	.20			1 1/2	1.000	1/2	3/4	3/4	

Case hardened worms have ground and polished threads (Indicated by letter "G" in catalog number).
Please Note: Stock Bore sizes on ground worms may be difficult to modify.

Worm and Worm Gears

12 Pitch • 1/2" Face • 14 1/2° Pressure Angle



Right Hand Double Thread (Stocked Right Hand Only)

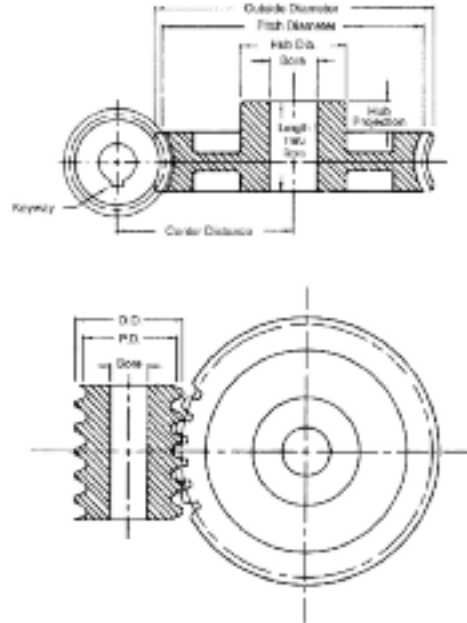

GEARS

Cast Iron and Bronze

Number Teeth	Catalog Number Cast Iron	Weight Pounds (App.)	Pitch Dia.	Bore (Inches)	Hub (Inches)		Style	Catalog Number Bronze	Wt. Lbs. (App.)
					Dia.	Proj.			
20	W1220D	.32	1.666	1/2	1 1/4	1/2	PLAIN	WB1220D	.40
30	W1230D	.78	2.500	3/4	1 1/2	5/8	PLAIN		
40	W1240D	1.3	3.333	3/4	1 3/4	3/4	W		

W = WEB



Steel — 9° 28' Helix Angle Worms

Catalog Number Soft	Weight Pounds (App.)	Catalog Number Hardened	Weight Pounds (App.)	Face (Inches)	Pitch Dia.	Bore (Inches)	Hub (Inches)		Keyway (Inches)
							Dia.	Proj.	
W12D	.14	WG12D	.14	1 1/2	1.000	3/8	3/8	3/8	1/8 x 1/16
WH12D	.20			1 1/2	1.000	1/2	1/2	1/2	

Case hardened worms have ground and polished threads (Indicated by letter "G" in catalog number).
Please Note: Stock Bore sizes on ground worms may be difficult to modify.



Worm and Worm Gears

12 Pitch • 1/2" Face • 14 1/2° Pressure Angle

Right Hand Quadruple Thread (Stocked Right Hand Only)

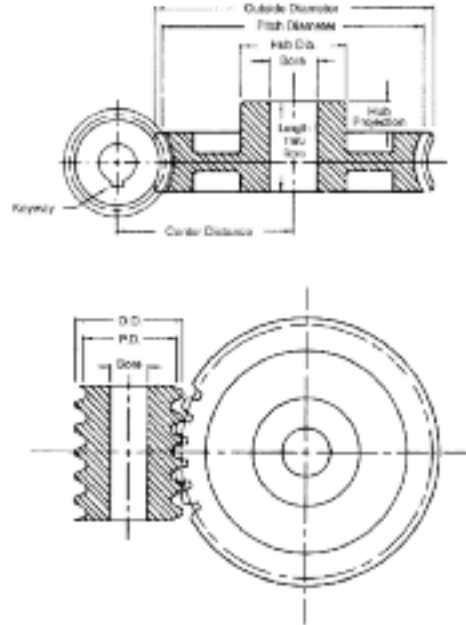

Cast Iron

Number Teeth	Catalog Number Cast Iron	Weight Pounds (App.)	Pitch Dia.	Bore (Inches)	Hub (Inches)		Style
					Dia.	Proj.	
20	W1220Q	.32	1.666	1/2	1 1/4	1/2	PLAIN
30	W1230Q	.38	2.500	3/4	1 1/2	5/8	PLAIN
40	W1240Q	.80	3.333	3/4	1 3/4	5/8	W

W = WEB



Steel — 18° 26' Helix Angle Worms

Catalog Number Soft	Weight Pounds (App.)	Catalog Number Hardened	Weight Pounds (App.)	Face (Inches)	Pitch Dia.	Bore (Inches)	Hub (Inches)		Keyway (Inches)
							Dia.	Proj.	
W12Q	.14	WG12Q	.14	1 1/2	1.000	5/8	1 1/4	1/2	1/8 x 1/16
WH12Q	.20			1 1/2	1.000	1/2	1 1/4	1/2	

Worm and Worm Gears

16 Pitch • $\frac{5}{16}$ " Face • $14\frac{1}{2}^\circ$ Pressure Angle

Right Hand Single Thread (Stocked Right Hand Only)

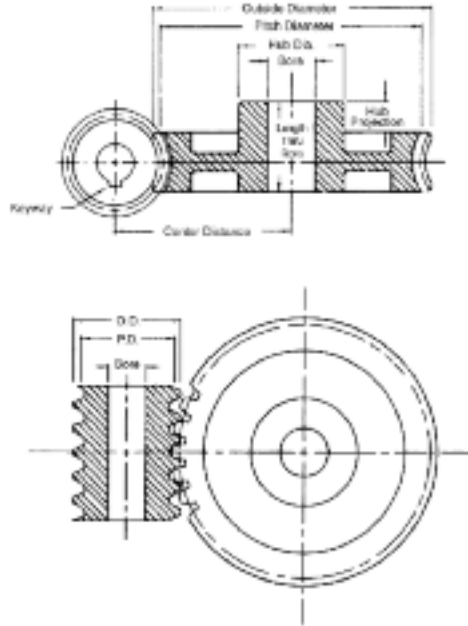

GEARS

Bronze

Number Teeth	Catalog Number	Weight Pounds (App.)	Pitch Dia.	Bore (Inches)	Hub (Inches)		Style
					Dia.	Proj.	
20	WB1620	.13	1.250	$\frac{1}{4}$	$\frac{5}{8}$	$\frac{5}{16}$	PLAIN
30	WB1630	.28	1.875	$\frac{5}{16}$	$\frac{3}{4}$	$\frac{3}{8}$	W
40	WB1640	.42	2.500	$\frac{5}{16}$	$\frac{3}{4}$	$\frac{3}{8}$	W
50	WB1650	.50	3.125	$\frac{3}{8}$	$\frac{7}{8}$	$\frac{7}{16}$	W

W = WEB



Steel — 5° 43' Helix Angle Worms

Catalog Number Soft	Weight Pounds (App.)	Catalog Number Hardened	Weight Pounds (App.)	Face (Inches)	Pitch Dia.	Bore (Inches)	Hub (Inches)	
							Dia.	Proj.
WH16	.08	WHG16	.07	1	.625	$\frac{1}{4}$.46	$\frac{1}{4}$
				1	.625	$\frac{5}{16}$.46	$\frac{1}{4}$

Case hardened worms have ground and polished threads (Indicated by letter "G" in catalog number).

Please Note: Stock Bore sizes on ground worms may be difficult to modify.

Right Hand Double Thread (Stocked Right Hand Only)

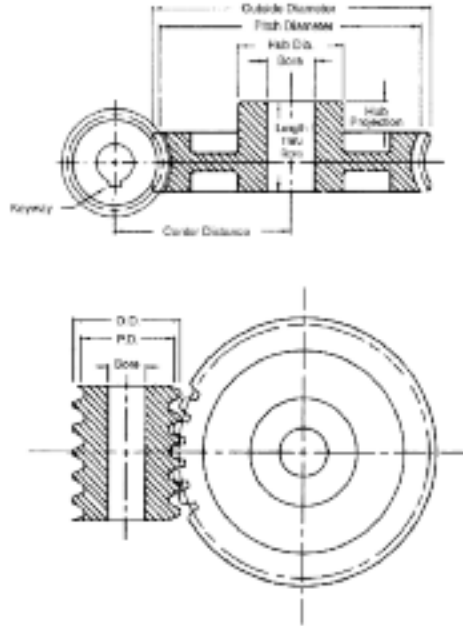

Bronze

Number Teeth	Catalog Number	Weight Pounds (App.)	Pitch Dia.	Bore (Inches)	Hub (Inches)		Style
					Dia.	Proj.	
20	WB1620D	.14	1.250	$\frac{1}{4}$	$\frac{5}{8}$	$\frac{5}{16}$	PLAIN



Steel — $11^\circ 19'$ Helix Angle Worms

Catalog Number Soft	Weight Pounds (App.)	Face (Inches)	Pitch Dia.	Bore (Inches)	Hub (Inches)	
					Dia.	Proj.
WH16D	.09	1	.625	$\frac{1}{4}$.46	$\frac{1}{4}$

Worm and Worm Gears

16 Pitch • $\frac{5}{16}$ " Face • $14\frac{1}{2}^\circ$ Pressure Angle



Right Hand Quadruple Thread (Stocked Right Hand Only)

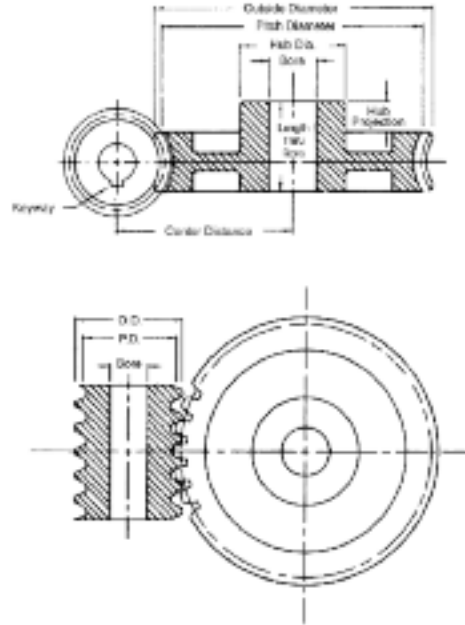

GEARS

Bronze

Number Teeth	Catalog Number	Weight Pounds (App.)	Pitch Dia.	Bore (Inches)	Hub (Inches)		Style
					Dia.	Proj.	
20	WB1620Q	.14	1.250	$\frac{1}{4}$	$\frac{5}{16}$	$\frac{5}{16}$	PLAIN



Steel — $21^\circ 48'$ Helix Angle Worms

Catalog Number Soft	Weight Pounds (App.)	Face (Inches)	Pitch Dia.	Bore (Inches)	Hub (Inches)	
					Dia.	Proj.
WH16Q	.08	1	.625	$\frac{1}{4}$.46	$\frac{1}{4}$



Worm Gears

Ratio-Center Distance Listings With Approximate Horsepower and Torque† Ratings for Hardened and Ground Worms With Bronze Worm Gears

RPM of Worm		*Gear	1800		900		300		100	
Center			Input-Output		Input-Output		Input-Output		Input-Output	
Ratio	Distance		HP	Torque	HP	Torque	HP	Torque	HP	Torque
5.0	.938	WB1620Q	.37	60	.25	70	.09	80	.03	80
5.0	1.333	WB1220Q	.80	130	.55	170	.25	200	.08	215
5.0	1.625	WB1020Q	1.25	200	.90	275	.40	350	.15	370
5.0	2.000	WB820Q	2.00	315	1.50	460	.80	890	.33	965
5.0	2.667	WB620Q	3.70	600	2.75	880	1.40	1280	.55	1430
6.0	3.000	WB624Q	4.50	880	3.40	1300	1.75	1900	.70	2180
7.5	1.250	WB1630Q	.50	130	.33	160	.14	180	.05	185
7.5	1.750	WB1230Q	1.25	300	.85	390	.33	460	.13	490
7.5	2.125	WB1030Q	1.90	450	1.33	560	.60	790	.25	850
7.5	2.625	WB830Q	3.00	725	2.25	1060	1.00	1400	.40	1520
7.5	3.500	WB630Q	5.75	1400	4.33	2060	2.20	2960	.87	3330
9.67	4.050	WB529T	8.40	2615	6.25	3785	3.33	5730	1.33	6540
10.0	.938	WB1620D	.25	70	.15	85	.06	90	.02	95
10.0	1.333	WB1220D	.50	155	.33	205	.16	240	.06	250
10.0	1.562	WB1640Q	.75	240	.50	285	.18	320	.06	330
10.0	1.625	WB1020D	.80	230	.60	325	.25	400	.10	430
10.0	2.000	WB820D	1.25	365	.90	525	.45	690	.15	750
10.0	2.167	WB1240Q	1.67	530	1.10	700	.50	830	.17	880
10.0	2.625	WB1040Q	2.50	805	1.75	1120	.80	1400	.30	1500
10.0	2.667	WB620D	2.40	735	1.80	1075	.95	1540	.37	1700
10.0	3.250	WB840Q	4.00	1300	3.00	1880	1.40	2500	.50	2700
10.0	4.333	WB640Q	7.75	2500	5.75	3675	3.00	5333	1.15	5980
12.0	3.000	WB624D	2.85	1050	2.20	1550	1.15	2200	.45	2450
12.5	1.875	WB1650Q	.95	375	.60	445	.25	500	.08	515
12.5	2.583	WB1250Q	2.00	820	1.40	1080	.60	1300	.20	1370
12.5	3.125	WB1050Q	3.00	1250	2.25	1740	1.00	2200	.33	2340
12.5	3.875	WB850Q	4.90	2000	3.70	2900	1.70	3840	.65	4170
12.5	5.167	WB650Q	9.50	3800	7.00	5600	3.60	8200	1.40	9200
13.33	5.150	WB540T	11.00	4720	8.20	6830	4.40	10360	1.75	11800
15.0	1.250	WB1630D	.33	155	.25	180	.08	200	.03	210
15.0	1.750	WB1230D	.75	350	.50	450	.25	535	.07	560
15.0	2.125	WB1030D	1.20	520	.87	725	.37	900	.15	965
15.0	2.188	WB1660Q	1.10	570	.70	680	.25	760	.10	790
15.0	2.625	WB830D	1.67	750	1.25	1080	.60	1415	.25	1530
15.0	3.000	WB1260Q	2.50	1170	1.67	1540	.70	1800	.25	1930
15.0	3.500	WB630D	3.50	1620	2.70	2375	1.40	3370	.55	3770
15.0	3.625	WB1060Q	3.75	1700	2.67	2500	1.17	3100	.50	3300
15.0	4.500	WB860Q	5.75	2820	4.33	4100	2.00	5470	.75	6000
15.0	6.000	WB660Q	11.33	5550	8.50	8000	4.33	11700	1.70	13100
16.67	6.150	WB550T	13.50	7250	10.00	10500	5.40	16000	2.20	18000
18.0	5.000	WB318	6.00	3100	4.67	4570	3.00	8000	1.50	10000
18.0	7.000	WB672Q	13.50	7800	10.00	11400	5.00	16500	2.00	18500
20.0	.938	WB1620	.15	75	.10	90	.04	100	.02	105
20.0	1.333	WB1220	.33	170	.25	220	.10	260	.04	275
20.0	1.562	WB1640D	.50	270	.30	310	.10	350	.04	350
20.0	1.625	WB1020	.50	250	.33	350	.20	440	.07	470

* Ratings listed are for bronze worm gears operating with hardened and ground steel worms. For ratings of cast iron worm gears with hardened steel worm, multiply listed ratings by 30%. For cast iron with hardened and ground steel worm, multiply by 50%.

† Torque ratings in inch pounds.

Worm Gears



Ratio-Center Distance Listings With Approximate Horsepower and Torque† Ratings for Hardened and Ground Worms With Bronze Worm Gears

RPM of Worm		*Gear	1800		900		300		100	
Center			Input-Output		Input-Output		Input-Output		Input-Output	
Ratio	Distance		HP	Torque	HP	Torque	HP	Torque	HP	Torque
20	2.000	WB820	.75	400	.60	600	.33	775	.12	850
20	2.167	WB1240D	1.00	600	.67	775	.33	920	.10	970
20	2.625	WB1040D	1.50	900	.85	1230	.50	1500	.20	1650
20	2.667	WB620	1.50	800	1.15	1170	.75	1660	.25	1850
20	2.812	WB1680Q	1.40	900	.90	1075	.33	1200	.12	1240
20	3.250	WB840D	2.30	1400	1.75	2000	.80	2580	.33	2800
20	3.833	WB1280Q	3.12	2000	2.12	2600	.90	3120	.33	3300
20	4.000	WB420	3.50	2000	2.75	2880	1.75	4700	.75	5600
20	4.333	WB640D	4.50	2780	3.40	4050	1.75	5800	.70	6500
20	4.625	WB1080Q	4.75	3000	3.40	4250	1.50	5340	.50	5700
20	5.750	WB880Q	7.50	4800	5.60	7000	2.60	9400	1.00	10200
20	7.667	WB680Q	15.00	9500	10.75	13800	5.50	20000	2.20	22500
24	3.000	WB624	1.75	1120	1.33	1630	.75	2300	.33	2600
24	4.500	WB424	4.00	2800	3.00	4000	2.00	6600	.90	7800
24	6.000	WB324	7.50	5300	5.90	7750	3.90	13500	1.90	17000
25	1.875	WB1650D	.50	370	.33	470	.12	520	.05	540
25	2.583	WB1250D	1.20	890	.80	1150	.33	1380	.12	1450
25	3.125	WB1050D	1.80	1340	1.33	1850	.60	2300	.25	2500
25	3.438	WB16100Q	1.75	1300	1.00	1575	.40	1750	.12	1800
25	3.875	WB850D	3.00	2200	2.25	3250	1.00	4200	.40	4500
25	4.667	WB12100Q	3.67	2800	2.50	3660	1.00	4400	.40	4630
25	5.167	WB650D	5.50	4000	4.00	6000	2.15	8700	.87	9700
25	5.625	WB10100Q	5.70	4500	4.10	6380	1.75	8000	.67	8500
25	7.000	WB8100Q	10.00	9700	7.00	11500	4.00	17500	1.25	19000
25	9.333	WB6100Q	17.50	14250	13.00	20750	6.66	30000	2.60	33000
29	4.050	WB529	3.50	2800	2.75	4200	1.50	6300	.67	7000
30	1.250	WB1630	.20	160	.12	190	.06	210	.02	215
30	1.750	WB1230	.50	350	.33	450	.15	540	.06	570
30	2.125	WB1030	.70	530	.50	750	.25	925	.10	1000
30	2.188	WB1660	.60	590	.40	700	.15	760	.05	800
30	2.625	WB830	1.00	870	.85	1260	.40	1600	.17	1750
30	3.000	WB1260D	1.33	1230	1.00	1600	.40	1900	.15	2000
30	3.500	WB630	2.00	1700	1.60	2430	.87	3500	.33	3800
30	3.625	WB1060D	2.00	1850	1.50	2500	.70	3200	.25	3430
30	4.500	WB860D	3.25	2900	2.50	4300	1.12	5650	.50	6000
30	6.000	WB660D	6.30	5800	4.80	6075	2.50	12110	1.00	13510
30	7.000	WB330	9.05	7880	7.00	11570	4.60	20280	2.25	25560
32	5.500	WB432	5.15	4680	4.00	6750	2.50	11140	1.10	13200
36	4.000	WB636	2.33	2310	1.80	3380	1.00	4800	.42	5360
36	7.000	WB672D	7.25	8010	5.50	11670	2.87	16700	1.15	18650
36	8.000	WB336	10.40	10900	8.10	15960	5.35	27950	2.60	35280
40	1.562	WB1640	.25	266	.12	330	.07	350	.02	360
40	2.167	WB1240	.55	580	.30	825	.18	900	.07	940
40	2.625	WB1040	.87	890	.65	1220	.30	1520	.12	1630
40	2.812	WB1680D	.75	910	.33	1140	.20	1200	.07	1230

* Ratings listed are for bronze worm gears operating with hardened and ground steel worms. For ratings of cast iron worm gears with hardened steel worm, multiply listed ratings by 30%. For cast iron with hardened and ground steel worm, multiply by 50%.

† Torque ratings in inch pounds.



Worm Gears

Ratio-Center Distance Listings With Approximate Horsepower and Torque† Ratings for Hardened and Ground Worms With Bronze Worm Gears

RPM of Worm			1800		900		300		100	
Center		*Gear	Input-Output		Input-Output		Input-Output		Input-Output	
Ratio	Distance		HP	Torque	HP	Torque	HP	Torque	HP	Torque
40	3.250	WB840	1.35	1440	.85	2350	.50	2700	.20	2900
40	3.833	WB1280D	1.70	2040	1.15	2675	.50	3160	.20	3330
40	4.333	WB640	2.50	2770	2.00	4033	1.00	5760	.45	6420
40	4.625	WB1080D	2.60	3070	1.90	4270	.85	5315	.33	5680
40	5.150	WB540	4.33	4930	3.40	7145	2.00	10725	.83	12170
40	5.750	WB880D	4.00	4740	3.00	6850	1.40	8940	.55	9680
40	6.500	WB440	6.00	5520	4.65	7950	3.00	13200	1.33	15480
40	7.667	WB680D	7.83	9600	6.00	14000	3.00	20025	1.25	22340
48	3.750	WB848	1.50	1950	1.20	2820	.60	3650	.25	3960
48	5.000	WB648	2.80	3730	2.25	5460	1.25	7750	.50	8640
48	7.500	WB448	6.80	9320	5.25	13400	3.33	22200	1.50	26160
48	10.000	WB348	12.70	17640	9.87	25920	6.50	45360	3.16	57120
50	1.875	WB1650	.30	380	.20	450	.08	490	.03	515
50	2.583	WB1250	.66	840	.50	1090	.20	1300	.08	1360
50	3.125	WB1050	1.00	1280	.75	1770	.33	2200	.14	2340
50	3.438	WB16100D	.90	1290	.50	1525	.25	1690	.08	1730
50	3.875	WB850	1.60	2140	1.25	3130	.66	4090	.25	4430
50	4.667	WB12100D	2.00	2875	1.33	3600	.50	4460	.22	4700
50	5.167	WB650	2.90	4000	2.25	5825	1.25	8310	.50	9260
50	5.625	WB10100D	3.00	4440	2.16	6110	1.00	7675	.33	8000
50	6.150	WB550	5.12	7120	4.00	10320	2.25	15480	1.00	17570
50	7.000	WB8100D	4.10	5000	2.75	7500	1.50	8000	.60	10000
50	9.333	WB6100D	9.00	13800	6.75	20200	3.50	28930	1.40	32280
54	11.000	WB354	13.50	21230	10.50	31200	7.00	54480	3.33	68760
59	7.050	WB559	5.50	9230	4.50	13900	2.50	20075	1.00	23160
60	2.188	WB1660	.33	550	.20	650	.08	720	.03	740
60	3.000	WB1260	.75	1100	.50	1440	.25	1700	.09	1790
60	3.625	WB1060	1.00	1690	.80	2330	.33	2890	.16	3080
60	4.500	WB860	1.66	2660	1.33	3900	.66	5090	.25	5500
60	6.000	WB660	320 5240	2.50	7670 1.40	1080	.60	1225		
64	9.500	WB464	7.87	14280	6.00	20640	3.80	34080	1.70	40320
72	7.000	WB672	3.33	6610	2.50	9660	1.50	13700	.60	15360
80	2.812	WB1680	.33	705	.22	830	.09	920	.04	950
80	3.833	WB1280	.75	1550	.50	2030	.25	2375	.10	2520
80	4.625	WB1080	1.15	2375	.87	3275	.40	4050	.16	4330
80	5.750	WB880	1.80	3800	1.40	5500	.70	7140	.30	7750
80	7.667	WB680	3.33	7380	2.66	10750	1.50	15350	.60	17110
96	6.750	WB896	1.50	4200	1.00	6000	.50	7000	.20	8500
96	9.000	WB696	3.25	8490	2.50	12370	1.33	17660	.50	19680
100	3.438	WB16100	.33	810	.20	960	.09	1060	.33	1100
100	4.667	WB12100	.75	1790	.50	2330	.25	2730	.90	2800
100	5.625	WB10100	1.00	2780	.80	3850	.33	4775	.16	5100
100	7.000	WB8100	1.67	4450	1.25	6300	.67	8000	.24	9000
100	9.333	WB6100	3.20	8700	2.50	12675	1.33	18090	.55	20160

* Ratings listed are for bronze worm gears operating with hardened and ground steel worms. For ratings of cast iron worm gears with hardened steel worm, multiply listed ratings by 30%. For cast iron with hardened and ground steel worm, multiply by 50%.

† Torque ratings in inch pounds.